

ACE

Gas Springs

*Your Best Solution for Lifting Lids,
Hoods, Panels and Guards*

*Includes New Line of Stainless Steel Models
for Packaging, Food Processing, Medical,
Marine and More*

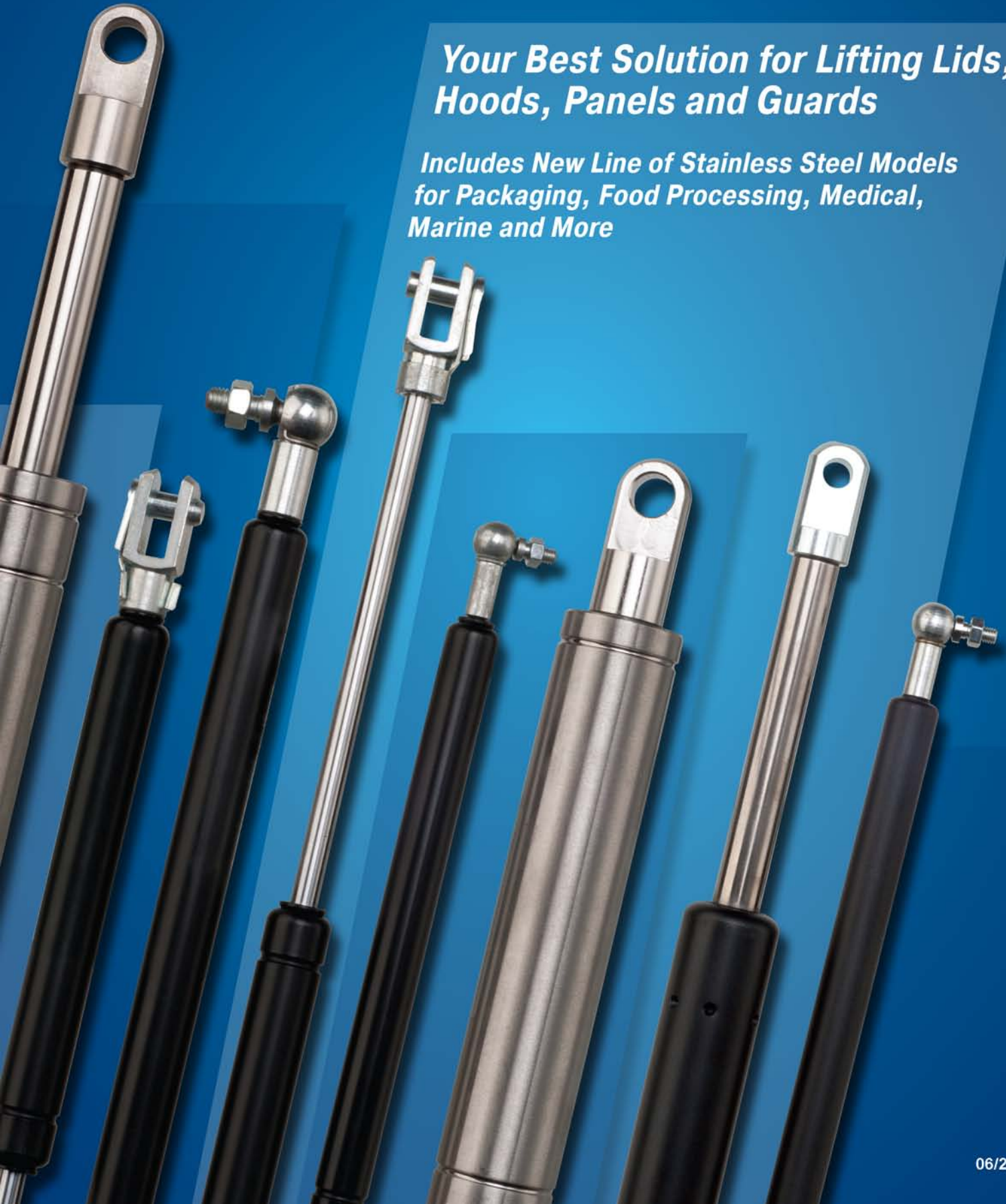

Gas springs are universally accepted, wherever you want to

- push
- pull
- lift
- lower, or
- position

covers, lids or other components by hand without using an external energy source. ACE gas springs are individually filled to a predetermined pressure to suit a customer's requirement (extension Force F_1). The cross-sectional area of the piston rod and filling pressure determines the extension force $F = p \cdot A$. During the compression of the piston rod, nitrogen flows through an orifice in the piston. The nitrogen is compressed by the volume of the piston rod. As the piston rod is compressed the pressure increases, so increasing the reaction force (progression). The force depends on the proportional relationship between the piston rod and the inside tube diameter, which is approximately linear.

Force-Stroke Characteristics of Gas Spring (Push Type)

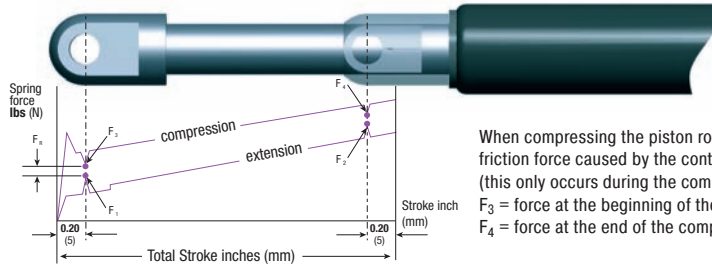

When compressing the piston rod, there is an additional friction force caused by the contact pressure of the seals (this only occurs during the compression stroke) F_R
 F_3 = force at the beginning of the compression stroke
 F_4 = force at the end of the compression stroke

F_1 = nominal force at 68 °F (20 °C) – this is the pressure figure normally used when specifying the gas spring

F_2 = force in the complete compressed position

Force-Stroke Characteristics of Traction Gas Spring (Pull Type)

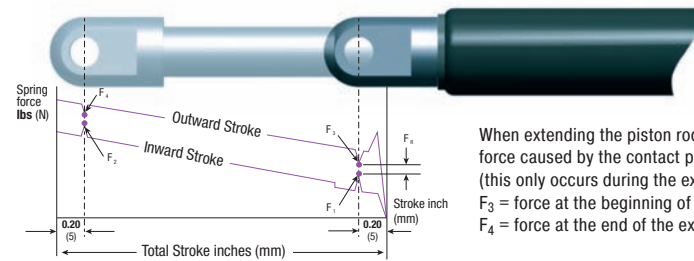

When extending the piston rod, there is an additional friction force caused by the contact pressure of the seals (this only occurs during the extension stroke) F_R
 F_3 = force at the beginning of the extension stroke
 F_4 = force at the end of the extension stroke

F_1 = nominal force at 68 °F (20 °C) this is the pressure figure normally used when specifying the gas spring

F_2 = force in the complete extended position

Gas Springs (Push Type)

| Type | ¹ Progression approx. % |
|-------|------------------------------------|
| GS-8 | 28 |
| GS-10 | 20 |
| GS-12 | 25 |
| GS-15 | 27 |
| GS-19 | 36 - 42 ³ |
| GS-22 | 39 - 50 ³ |
| GS-28 | 60 - 95 ³ |
| GS-40 | 47 - 53 ³ |
| GS-70 | 25 |

Gas Springs (Pull Type)

| Type | ¹ Progression approx. % |
|--------|------------------------------------|
| AGS-15 | 35 |
| AGS-19 | 37 - 41 ² |
| AGS-22 | 50 - 56 ² |
| AGS-28 | 48 - 52 ² |

Gas Springs (Pull Type)

| Type | ¹ Progression approx. % |
|-------|------------------------------------|
| GZ-15 | 23 |
| GZ-19 | 10 |
| GZ-28 | 20 |
| GZ-40 | 40 |

¹ The progression (the slope of the force line in the diagrams above) is due to the reduction of the internal gas volume as the piston rod moves from its initial position to its fully stroked position. The approx. progression values given for standard springs can be altered on request.

Effect of temperature: The nominal F_1 figure is given at 68 °F (20 °C). An increase of 50 °F (10 °C) will increase force by 3.4%.

Force tolerance on F_1 force: ±7%

² Depending on the filling force.

³ Depending on the stroke.

Service Life

Force tolerance: ±7%

Effect of temperature: An increase in temperature of each 50 °F (10 °C) will increase force by approx. 3.4 %.

Temperature range: -4 °F (-20 °C) to 176 °F (+80 °C) – special seals from -49 °F (-45 °C) to 392 °F (200 °C)

Mounting: The gas springs should ideally be installed with the **piston rod pointing downwards** to use the end damping during the extension stroke to smoothly decelerate the motion of the gas spring. Some ACE gas springs have a uniquely designed front bearing with an integrated grease chamber allowing the gas spring to be mounted and operated in any position if required.

When fitting the gas springs ensure that the stroke is fully extended (GZ type fully compressed), this makes assembly and disassembly much easier. **Support the moving mass/flap during assembly or disassembly to prevent accidents. To avoid twisting or side loading, it is recommended that ball joints or other pivoted mounting attachments are used.** The mounting attachments must always be positively secured onto the threaded studs of the gas spring.

ACE gas springs are maintenance-free. DO NOT oil or grease the piston rod!

The piston rod must be protected from any hits, scratches or dirt and especially paint. Damage to the surface finish of the piston rod will destroy the sealing system and cause loss of pressure. The outer body must not be deformed or mechanically damaged.

ACE gas springs can be stored in any position. Experience has shown that long storage periods do not result in loss of pressure. However you may experience some "stiction" requiring a higher effort to move the gas spring for the first time after a long storage period.

Generally, ACE gas springs are tested to 70,000 strokes. This is equivalent to the seal lifetime (depending on model size) to a distance travelled of 1.24 miles (2 km) up to 6.21 miles (10 km). Depending upon the application and operating environment, the service life of these gas springs may be much longer. 500,000 strokes or more have been achieved on some applications.

Lifetime for traction gas springs see pages 34 to 37.

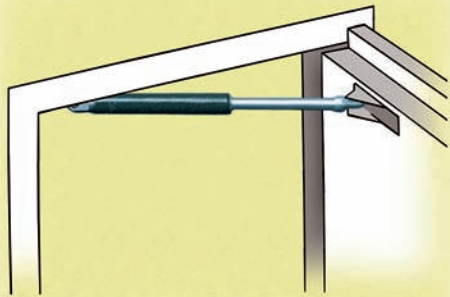

Doors open and close safely

ACE industrial gas springs make opening and closing doors of rescue helicopters easier.

The maintenance-free, sealed systems are installed in the access doors of helicopters of the type EC 135. There, they allow the crew to enter or exit the helicopter quickly, thus contributing to enhanced safety.

The **GS-19-300-CC** gas springs provide a defined retraction speed and secure engagement of the door lock. The integrated end position damper allows gentle closing of the door and saves wear and tear on the valuable, lightweight material.



Industrial gas springs: For safe entry and exit

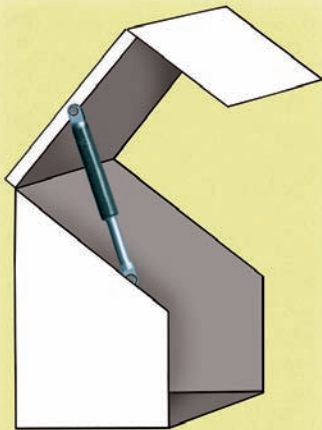

Protection under the hood

ACE industrial gas springs prevent injuries during maintenance work on harvesting machines.

The blades of corn pickers are arranged under plastic hoods, which assure proper material flow within the machine. For maintenance purposes, the hoods, weighing about 15 lbs (7 kg), must be lifted up. To protect maintenance personnel from injury by falling hoods, they are kept in the open position by industrial gas springs of the type **GS-22-250-DD**.

Another advantage they offer is their stability under rough operating conditions due to their wear-resistant coating on the piston rod and the coated housing.



Enhanced protection: Industrial gas springs secure heavy hoods

Stainless Steel Gas Springs in Yachts, Ships & Boats

are ideal for lifting large, heavy hatches, lids, panels, lockers, companionways and access doors.



ACE Gas Springs in military vehicles open heavy doors to help with quick ingress and egress of troops. Heavy hatches and panels are opened with minimal effort. *Gas spring added to image below for application example only.*



Industrial Gas Springs from ACE remove the need for muscle power and provide controlled lifting motion for large, heavy doors, covers, lids, machine guards and access panels on production machinery.

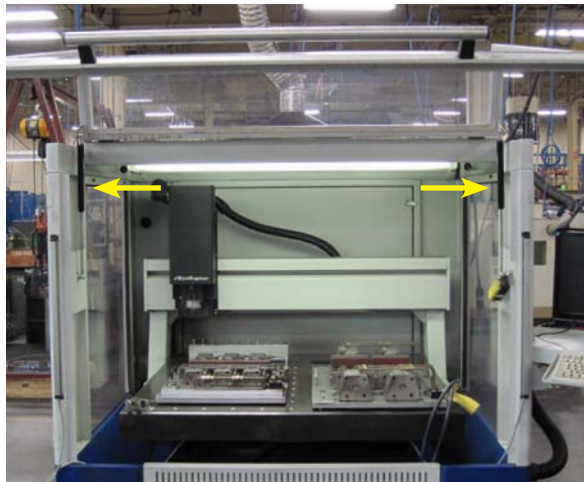

Gas Springs from ACE are utilized in commercial applications for lifting large entryway panels, as well as hatches, lids and panels on RVs, emergency vehicles and construction equipment



Where Gas Springs are Utilized...

Aerospace
Ambulances
Amusement Park Rides
Armored Cars
Awnings
Belt Tensioning
Bottling
Buses
Campers & Travel Trailers
Cargo Doors

Conveyor Walkthroughs
Counterbalance
Fire Escape Hatches
Fire Trucks
Fitness Equipment
Folding Beds
Folding Treadmills
Furniture Chest Lids
Gurney Beds
Lids, Hoppers & Feeders

Lifting
Lowering
Machine Guards
Medical Equipment
Military Vehicles
Off Road Machinery
Printing
Recreational Vehicles
Roof Ventilation Hatches
Safety Covers

Seat Damping
Seats
Skylights
Stair Lifts
Sun Roofs
Tilting
Toolboxes
Truck/Bus Engine covers
TV Screen Supports
Windows

Calculation

To obtain the ideal selection to give the optimum operation for a gas spring it is important to identify the following points:

- gas spring size
- required gas spring stroke
- mounting points on flap and frame
- extended length of the gas spring
- required extension force
- hand forces throughout the complete movement on the flap

With our **free calculation service** you can eliminate the time-consuming calculation and send us your details by fax or e-mail. Just complete the information shown on the calculation formula page number 6. Please attach a sketch of your application (a simple hand sketch is sufficient) in side view. Our application engineers will determine the optimum gas springs and mounting points and calculate the ideal situation to satisfy your requirements.

You will receive a quotation showing the opening and closing forces and our recommended mounting points to suit your application.

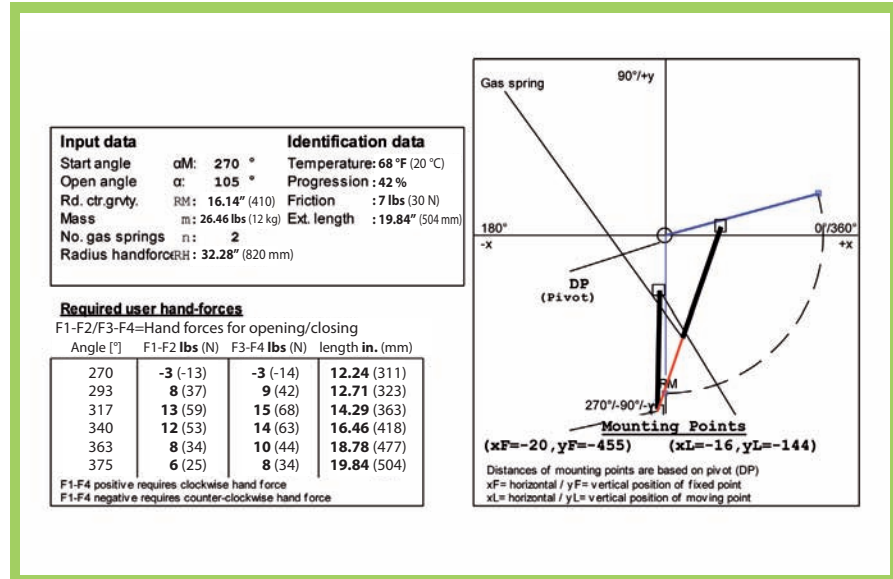

"Calculation offer with all required details for assembly!"



Safety Instructions

Gas springs are filled with nitrogen gas. Nitrogen is an inert gas that does not burn or explode and is not poisonous.

Please note!: the internal pressure of gas springs can be up to 4,350 psi (300 bar). Do not attempt to open or modify them.

ACE gas springs will operate in surrounding temperatures from -4 °F (-20 °C) to 176 °F (+80 °C). We can equip our springs with special seals to withstand temperatures as low as -49 °F (-45 °C) or as high as 392 °F (+200 °C). Gas springs should not be placed over heat or in open fire!

Disposal/Recycling: Gas Springs consist mostly of metal and the metal could be recycled, but first the gas pressure must be removed. Please ask for our disposal recommendations which advise how to depressurize the gas springs and make them safe to recycle.

All gas springs are marked with the part number, the production date and a warning sign "Do not open high pressure". We are not responsible for any damages of any kind that arises due to goods that are not marked accordingly.

Gas springs should be installed with the piston rod downwards. This position ensures best damping quality. **Only ACE gas springs include an integrated grease chamber which allows for alternative mounting opportunities.**

Gas springs should not be exposed to tilting or side load forces during operation or whilst static (this can cause bending of the piston rod or early wear).

Gas springs are maintenance-free. **Do not grease or oil the piston rod.**

The piston rod must not be painted and should be protected against shocks, scratches and dirt. The cylinder should not be deformed as such damage would destroy the sealing system.

ACE gas springs can be stored in any position. Pressure lost through long storage is not to be expected. There may be a sticking effect the first time you compress a spring. This may require a higher initial force to operate the gas spring for the first time (initial breakaway force).

The tolerance for the installation length is generally deemed to be $\pm .08"$ (± 2 mm). If very high demands are placed on durability and stability, please avoid the combination of small diameter + long stroke + high force.

The force tolerance is $\pm 7\%$.

Please send us a sketch with dimensions of your application!
Sketch is required in order to calculate.

Push type Pull type

Input date

Gas spring fixing points

The fixed point of the frame and the moving point of the flap are critical for the optimum operation.

Therefore please attach a sketch of your application (a few lines with their dimensions are sufficient)!







Moving mass* m _____ lbs (kg)
 Number of gas springs in parallel* n _____ pcs
 Number of movements* _____ / day
 Ambient temperature T _____ °F (°C)

If not shown by the sketch:

Radius of centre of gravity R_M _____ inches (mm)
 Radius of hand force R_H _____ inches (mm)
 Starting angle (0° to 360°) _____ °
 Opening angle (-360° to +360°) α _____ °
 (- = downwards, + = upwards)

* Compulsory information

Desired Mounting Fittings

| End Fitting | | End Fitting |
|-----------------------------------|---|-----------------------------------|
| <input type="checkbox"/> A |  | <input type="checkbox"/> A |
| <input type="checkbox"/> B |  Stud Thread | <input type="checkbox"/> B |
| <input type="checkbox"/> C |  Angle Ball Joint | <input type="checkbox"/> C |
| <input type="checkbox"/> D |  Clevis Fork | <input type="checkbox"/> D |
| <input type="checkbox"/> E |  Swivel Eye | <input type="checkbox"/> E |
| <input type="checkbox"/> F |  Inline Ball Joint | <input type="checkbox"/> F |
| <input type="checkbox"/> G |  Ball Socket | <input type="checkbox"/> G |

The end fittings are interchangeable.

e. g. -CE: C = Angle Ball Joint, E = Swivel Eye

Sketch: _____

Comments _____

Requirement per year _____

Machine type / reference _____

Sender

Company _____

Address _____

Internet _____

Dept. _____

Name _____

Telephone _____

Fax _____

E-Mail _____

**Please copy, complete and fax to ACE:
 Fax (248) 476-2470**

ACE industrial gas springs are maintenance-free and self-contained. They are available with body diameters from .31" (8 mm) up to 2.76" (70 mm), and forces from 2 lbs (10 N) up to 2,923 lbs (13,000 N) ex. stock. **ACE gas springs offer a high service life with a wear-resistant coating on the piston rod. Also an integrated low friction bearing with grease chamber which provides a very low break away force (GS-19 to GS-40).** It allows them to be mounted in any orientation, although rod downwards is preferable if you want to take advantage of the built-in end position damping. The valve allows the force to be adjusted to your specific requirements. A wide variety of interchangeable end fittings makes installation easy and versatile. ACE gas springs are universally applicable wherever you have lifting and lowering. They remove the need for "muscle power" and provide controlled motion for lids, hoods, machine guards etc. The ACE selection software quickly specifies the correct gas spring for your individual application and we can deliver, usually within 24 hours.



"Force adjustable to your specific requirements – with gas valve ex. stock!"

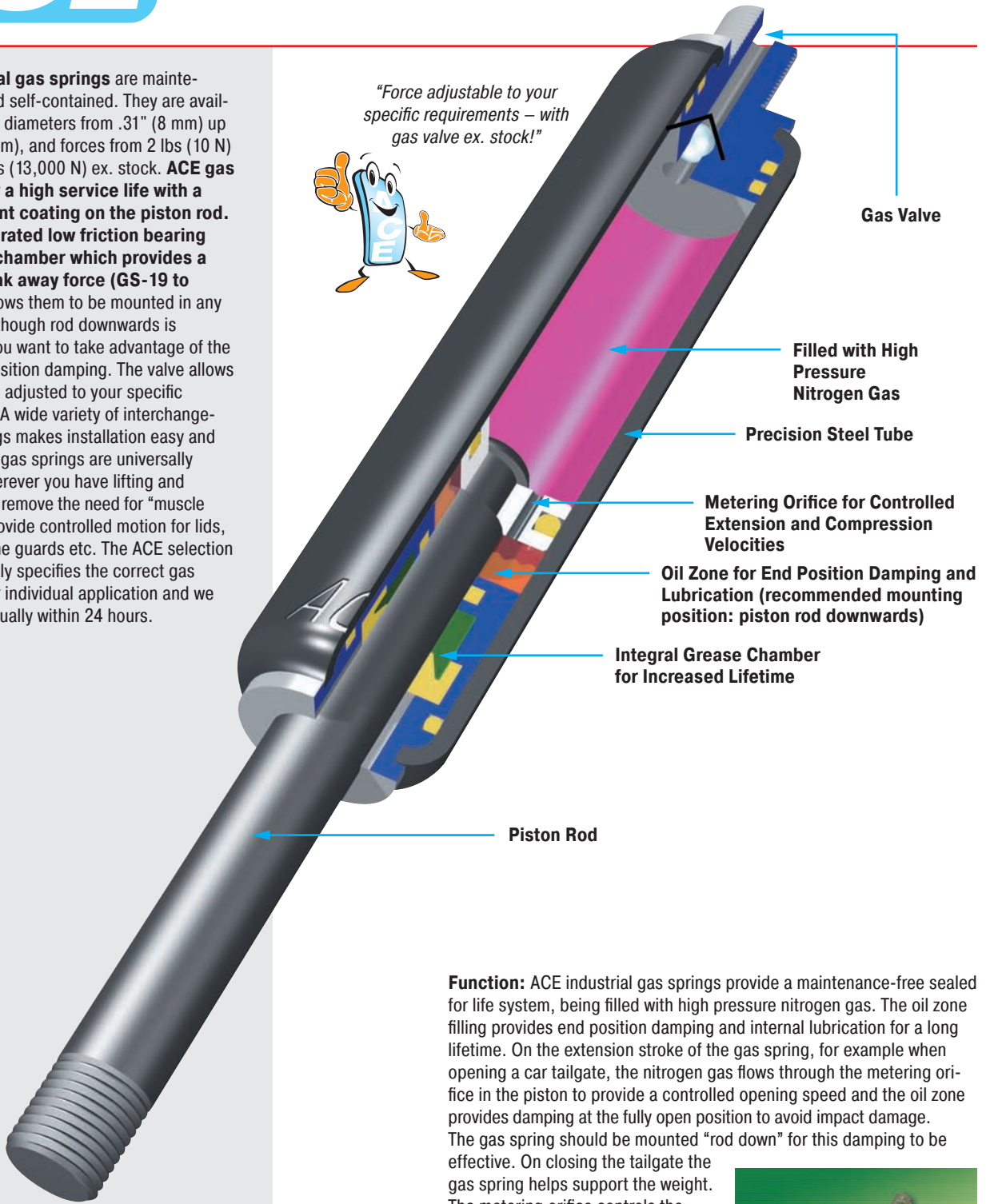

Function: ACE industrial gas springs provide a maintenance-free sealed for life system, being filled with high pressure nitrogen gas. The oil zone filling provides end position damping and internal lubrication for a long lifetime. On the extension stroke of the gas spring, for example when opening a car tailgate, the nitrogen gas flows through the metering orifice in the piston to provide a controlled opening speed and the oil zone provides damping at the fully open position to avoid impact damage. The gas spring should be mounted "rod down" for this damping to be effective. On closing the tailgate the gas spring helps support the weight. The metering orifice controls the extension and compression velocities of the gas spring.

Operating fluid: Nitrogen gas and oil

Mounting: In any position

Operating temperature range: -4 °F to +176 °F (-20 °C to +80 °C)

On request: Without damping, extended length damping, special force curves, special lengths, alternative end fittings.



Extension Forces 2 lbs to 22 lbs (10 N to 100 N)
[when Piston Rod Compressed up to 29 lbs (130 N)]

End Fitting

Standard Dimensions – inches and (mm)

End Fitting

A3,5

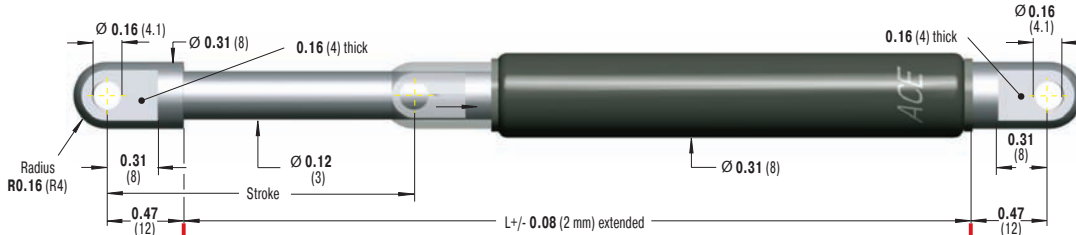

Eye A3,5
max. force 83 lbs (370 N)

B3,5



Dimensions

| Model | Stroke inches (mm) | L - extended inches (mm) |
|---------|-----------------------|-----------------------------|
| GS-8-20 | 0.79 (20) | 2.83 (72) |
| GS-8-30 | 1.18 (30) | 3.62 (92) |
| GS-8-40 | 1.57 (40) | 4.41 (112) |
| GS-8-50 | 1.97 (50) | 5.20 (132) |
| GS-8-60 | 2.36 (60) | 5.98 (152) |
| GS-8-80 | 3.15 (80) | 7.56 (192) |

Stud Thread B3,5

C3,5

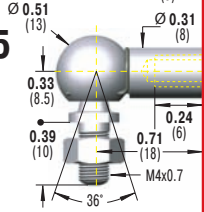

Angle Ball Joint C3,5
max. force 83 lbs (370 N)

D3,5

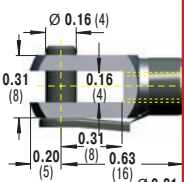

Clevis Fork D3,5
max. force 83 lbs (370 N)

E3,5

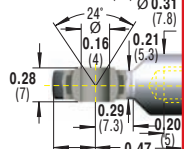

Swivel Eye E3,5
max. force 83 lbs (370 N)

G3,5

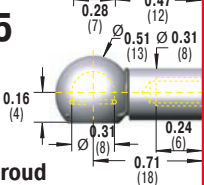

Ball Socket G3,5
max. force 83 lbs (370 N)

**Rod Shroud
W3,5-8**

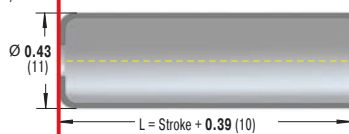

Ordering Example

Model (Push Type) _____
Body \varnothing 0.31" (8 mm) _____
Stroke 1.18" (30 mm) _____
Piston Rod End Fitting A3,5 _____
Body End Fitting C3,5 _____
Nominal Force F_1 7 lbs (30 N) _____

GS-8-30-AC-30

The end fittings are interchangeable.

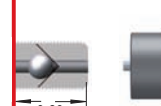
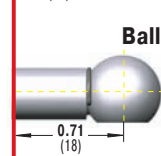
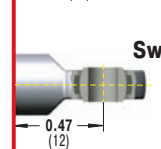
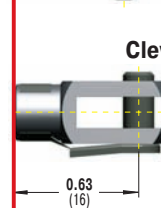
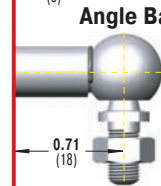
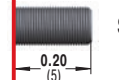

Adjuster Knob U3,5
See page 58.

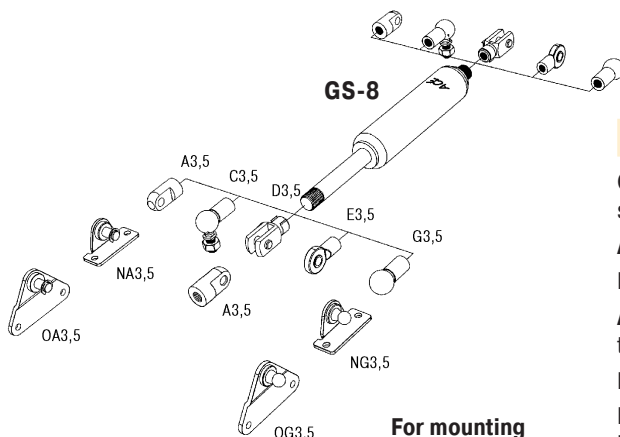

For mounting accessories see page 47.

Technical Data

On request: Without damping, extended length damping, special force curves, special lengths, alternative end fittings.

Available force range F_1 at 68 °F (20 °C): 2 lbs to 22 lbs (10 N to 100 N)

Mounting: In any position

Advice: We recommend mounting with piston rod downwards to take advantage of the built-in end position damping.

End position damping length: Approx. 0.2" (5 mm)

Material: Body: Black coated steel. Piston rod: Stainless steel (303). End fittings: Zinc plated steel.

Progression: Approx. 28 %, F_2 max. 29 lbs (130 N)

Extension Forces 2 lbs to 22 lbs (10 N to 100 N)
[when Piston Rod Compressed up to 27 lbs (120 N)]

End Fitting

Standard Dimensions – inches and (mm)

End Fitting

A3,5 Eye A3,5 max. force 83 lbs (370 N)

B3,5 Stud Thread B3,5

C3,5 Angle Ball Joint C3,5 max. force 83 lbs (370 N)

D3,5 Clevis Fork D3,5 max. force 83 lbs (370 N)

E3,5 Swivel Eye E3,5 max. force 83 lbs (370 N)

G3,5 Ball Socket G3,5 max. force 83 lbs (370 N)

U3,5 Adjuster Knob U3,5 See page 58.

Rod Shroud W3,5-10

Dimensions

| Model | Stroke inches (mm) | L - extended inches (mm) |
|----------|-----------------------|-----------------------------|
| GS-10-20 | 0.79 (20) | 2.83 (72) |
| GS-10-30 | 1.18 (30) | 3.62 (92) |
| GS-10-40 | 1.57 (40) | 4.41 (112) |
| GS-10-50 | 1.97 (50) | 5.20 (132) |
| GS-10-60 | 2.36 (60) | 5.98 (152) |
| GS-10-80 | 3.15 (80) | 7.56 (192) |

Ordering Example

Model (Push Type) _____ ↑
 Body Ø 0.39" (10 mm) _____ ↑
 Stroke 3.15" (80 mm) _____ ↑
 Piston Rod End Fitting A3,5 _____ ↑
 Body End Fitting C3,5 _____ ↑
 Nominal Force F₁ 13 lbs (60 N) _____ ↑

GS-10-80-AC-60

The end fittings are interchangeable.

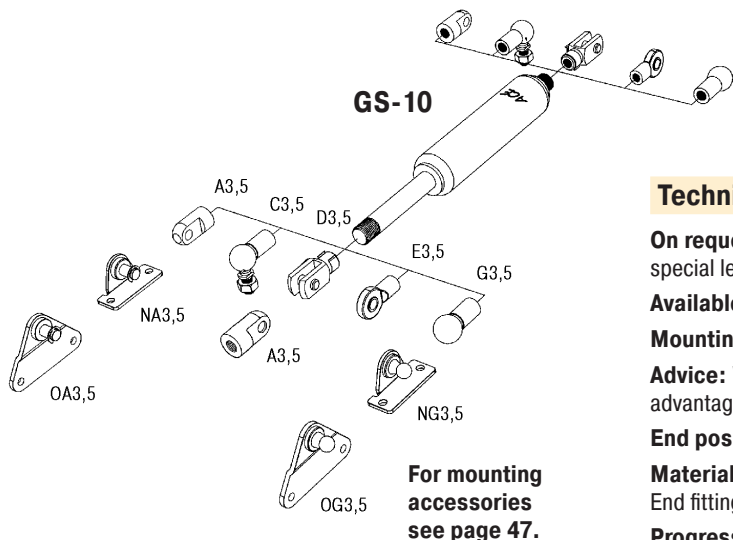

Technical Data

On request: Without damping, extended length damping, special force curves, special lengths, alternative end fittings.

Available force range F₁ at 68 °F (20 °C): 2 lbs to 22 lbs (10 N to 100 N)

Mounting: In any position

Advice: We recommend mounting with piston rod downwards to take advantage of the built-in end position damping.

End position damping length: Approx. 0.2" (5 mm)

Material: Body: Black coated steel. Piston rod: Stainless steel (303). End fittings: Zinc plated steel.

Progression: Approx. 28 %, F₂ max. 27 lbs (120 N)

End Fitting

Standard Dimensions – inches and (mm)

End Fitting

A3,5

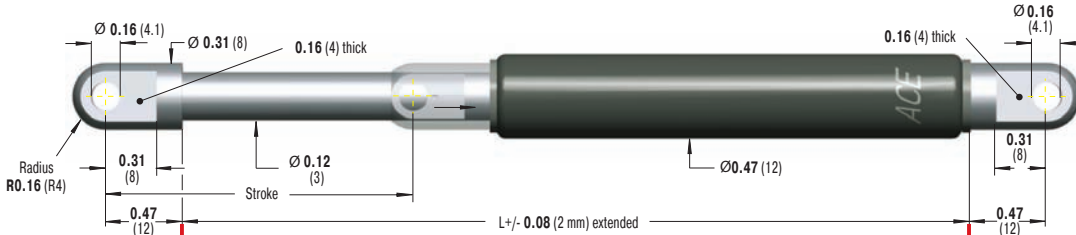

Eye A3,5
max. force 83 lbs (370 N)

B3,5

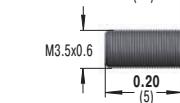

Stud Thread B3,5

C3,5

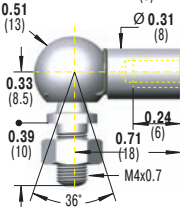

Angle Ball Joint C3,5
max. force 83 lbs (370 N)

D3,5

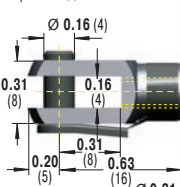

Clevis Fork D3,5
max. force 83 lbs (370 N)

E3,5

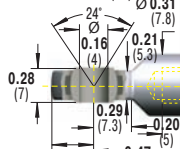

Swivel Eye E3,5
max. force 83 lbs (370 N)

G3,5

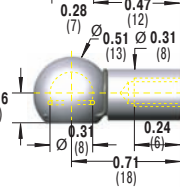

Ball Socket G3,5
max. force 83 lbs (370 N)

Rod Shroud W3,5-12

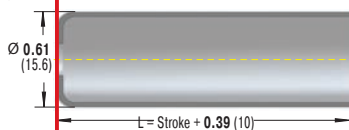

Dimensions

| Model | Stroke inches (mm) | L - extended inches (mm) | F ₁ max. lbs (N) |
|-----------|-----------------------|-----------------------------|--------------------------------|
| GS-12-20 | 0.79 (20) | 2.83 (72) | 40 (180) |
| GS-12-30 | 1.18 (30) | 3.62 (92) | 40 (180) |
| GS-12-40 | 1.57 (40) | 4.41 (112) | 40 (180) |
| GS-12-50 | 1.97 (50) | 5.20 (132) | 40 (180) |
| GS-12-60 | 2.36 (60) | 5.98 (152) | 40 (180) |
| GS-12-80 | 3.15 (80) | 7.56 (192) | 34 (150) |
| GS-12-100 | 3.94 (100) | 9.13 (232) | 34 (150) |
| GS-12-120 | 4.72 (120) | 10.71 (272) | 27 (120) |
| GS-12-150 | 5.91 (150) | 13.07 (332) | 22 (100) |

Ordering Example

GS-12-100-AA-30

Model (Push Type) _____
 Body Ø 0.47" (12 mm) _____
 Stroke 3.94" (100 mm) _____
 Piston Rod End Fitting A3,5 _____
 Body End Fitting A3,5 _____
 Nominal Force F₁ 7 lbs (30 N) _____

The end fittings are interchangeable.

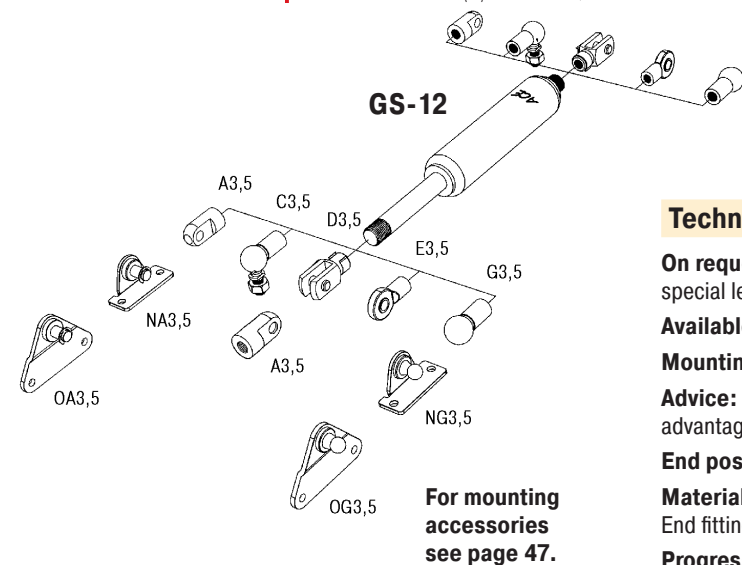
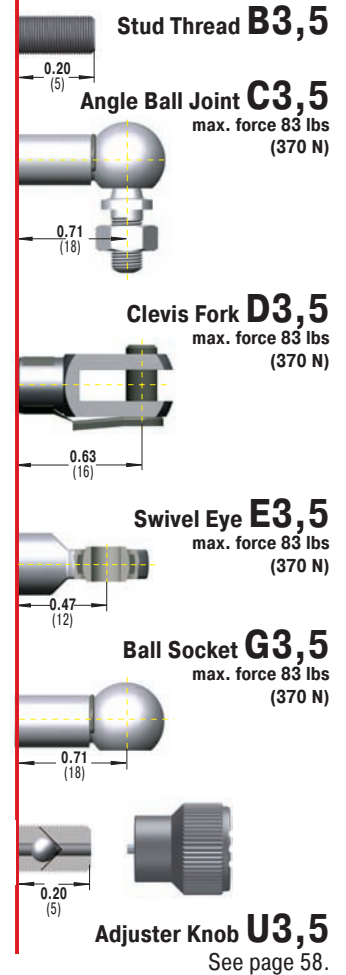

For mounting accessories see page 47.

Technical Data

On request: Without damping, extended length damping, special force curves, special lengths, alternative end fittings.

Available force range F₁ at 68 °F (20 °C): 2 lbs to 40 lbs (10 N to 180 N)

Mounting: In any position

Advice: We recommend mounting with piston rod downwards to take advantage of the built-in end position damping.

End position damping length: Approx. 0.39" (10 mm)

Material: Body: Black coated steel. Piston rod: Stainless steel (303). End fittings: Zinc plated steel.

Progression: Approx. 28 %, F₂ max. 51 lbs (225 N)

End Fitting

Standard Dimensions – inches and (mm)

End Fitting

End Fitting A
max. force 180 lbs (800 N)

End Fitting B
Stud Thread

End Fitting C
Angle Ball Joint
max. force 112 lbs (500 N)

End Fitting D
Clevis Fork
max. force 180 lbs (800 N)

End Fitting E
Swivel Eye
max. force 180 lbs (800 N)

End Fitting F
Inline Ball Joint
max. force 112 lbs (500 N)

End Fitting H
Ball Socket
max. force 112 lbs (500 N)

Optional gas pressure adjuster tool available, consult factory

Dimensions

| Model | Stroke inches (mm) | L - extended inches (mm) |
|------------|-----------------------|-----------------------------|
| AGS-15-60 | 2.36 (60) | 5.79 (147) |
| AGS-15-80 | 3.15 (80) | 7.36 (187) |
| AGS-15-100 | 3.94 (100) | 8.94 (227) |
| AGS-15-120 | 4.72 (120) | 10.51 (267) |
| AGS-15-150 | 5.91 (150) | 12.87 (327) |
| AGS-15-200 | 7.87 (200) | 16.81 (427) |

Ordering Example
AGS-15-150-AC-V-150

Model (Push Type) _____
 Body Ø 0.61" (15.6 mm) _____
 Stroke 5.91" (150 mm) _____
 Piston Rod End Fitting A _____
 Body End Fitting C _____
 Adjustable (V) _____
 Nominal Force F₁ 34 lbs (150 N) _____

The end fittings are interchangeable.

Optional A5 Eye – Imperial

max. force 180 lbs

Optional A5 Eye – Metric

max. force 800 N

Alternate Stroke Lengths Available, Consult Factory

| Model | Stroke inches (mm) | L - extended inches (mm) |
|----------|-----------------------|-----------------------------|
| GS-15-20 | 0.79 (20) | 2.64 (67) |
| GS-15-40 | 1.57 (40) | 4.21 (107) |
| GS-15-50 | 1.97 (50) | 5.00 (127) |

Rod Shroud W5-15
L = Stroke + .79 (20)

End Fitting A
max. force 180 lbs (800 N)

End Fitting B
Stud Thread

End Fitting C
Angle Ball Joint
max. force 112 lbs (500 N)

End Fitting D
Clevis Fork
max. force 180 lbs (800 N)

End Fitting E
Swivel Eye
max. force 180 lbs (800 N)

End Fitting F
Inline Ball Joint
max. force 112 lbs (500 N)

End Fitting H
Ball Socket
max. force 112 lbs (500 N)

Optional gas pressure adjuster tool available, consult factory

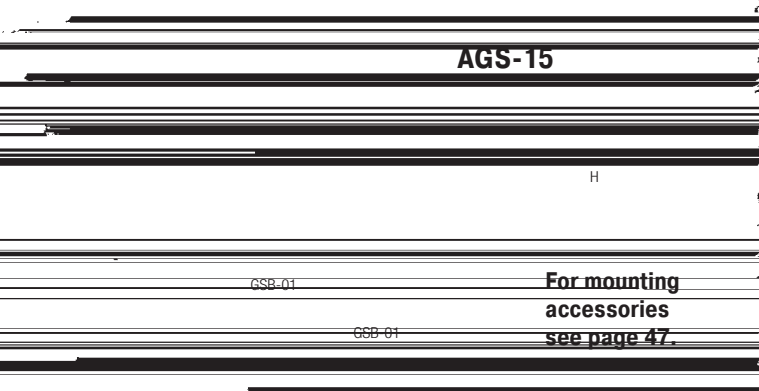

Technical Data

On request: Without damping, special damping, special lengths, strokes and alternative end fittings.

Available force range F₁ at 68 °F (20 °C): 2 lbs to 90 lbs (10 N to 400 N)

Mounting: In any position

Advice: We recommend mounting with piston rod downwards to take advantage of the built-in end position damping.

AGS end position damping length: Approx. 0.20" (5 mm)

GS end position damping length: Approx. 0.39" (10 mm)

Material: Body: Black coated steel. Piston rod: Steel, wear-resistant. GS models have chrome rods. End fittings: Zinc plated steel.

AGS force progression: Approx. 35%

GS force progression: Approx. 27%

End Fitting

Standard Dimensions – inches and (mm)

End Fitting

Dimensions

| Model | Stroke inches (mm) | L - extended inches (mm) |
|------------|-----------------------|-----------------------------|
| AGS-19-100 | 3.94 (100) | 10.39 (264) |
| AGS-19-150 | 5.91 (150) | 14.33 (364) |
| AGS-19-200 | 7.87 (200) | 18.28 (464) |
| AGS-19-250 | 9.84 (250) | 22.20 (564) |

Ordering Example

Model (Push Type) AGS-19-150-AC-V-600

Body Ø 0.75" (19 mm)

Stroke 5.91" (150 mm)

Piston Rod End Fitting A

Body End Fitting C

Adjustable (V)

Nominal Force F₁ 135 lbs (600 N)

The end fittings are interchangeable.

***G Angle Ball Joint has 5/16-18 Imperial Thread**

Eye A
max. force 674 lbs (3,000 N)

Stud Thread B

Angle Ball Joint C, *G
max. force 270 lbs (1,200 N)

***G 5/16-18 Imperial Thread Available**

Clevis Fork D
max. force 674 lbs (3,000 N)

Swivel Eye E
max. force 674 lbs (3,000 N)

Inline Ball Joint F
max. force 270 lbs (1,200 N)

Ball Socket H
max. force 270 lbs (1,200 N)

Optional gas pressure adjuster tool available, consult factory

Alternate Stroke Lengths Available, Consult Factory

| Model | Stroke inches (mm) | L - extended inches (mm) |
|-----------|-----------------------|-----------------------------|
| GS-19-50 | 1.97 (50) | 6.46 (164) |
| GS-19-300 | 11.81 (300) | 26.14 (664) |

Rod Shroud W8-19

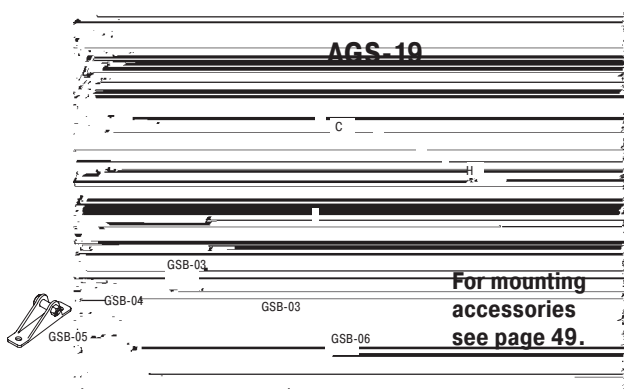

Technical Data

On request: Without damping, special damping, special lengths, strokes and alternative end fittings.

Available force range F₁ at 68 °F (20 °C): 11 lbs to 157 lbs (50 N to 700 N)

Mounting: In any position

Advice: We recommend mounting with piston rod downwards to take advantage of the built-in end position damping.

AGS end position damping length: Approx. 0.20" (5 mm)

GS end position damping length: Strong end position damping approx. 0.79" to 2.36" (20 to 60 mm) – depending on the stroke – and slow extension speed.

Material: Body: Black coated steel. Piston rod: Steel, wear-resistant. GS models have chrome rods. End fittings: Zinc plated steel.

AGS force progression: Approx. 37% to 41%

GS force progression: Approx. 36% to 42%

End Fitting

Standard Dimensions – inches and (mm)

End Fitting

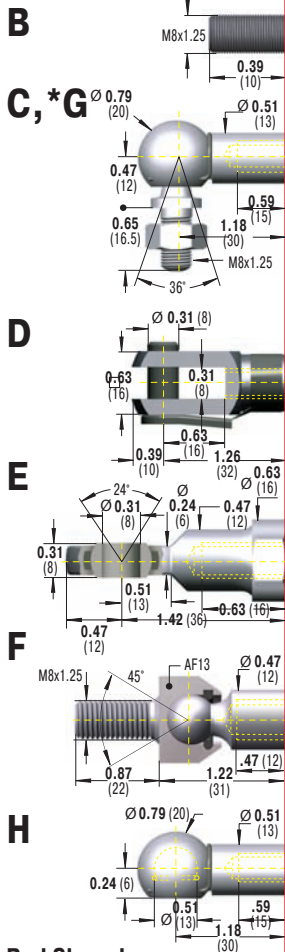
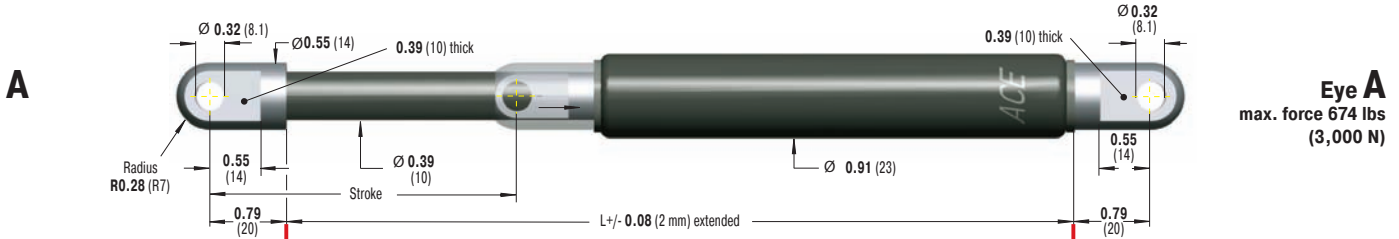

| Dimensions | | |
|------------|-----------------------|-----------------------------|
| Model | Stroke inches (mm) | L - extended inches (mm) |
| AGS-22-100 | 3.94 (100) | 10.39 (264) |
| AGS-22-150 | 5.91 (150) | 14.33 (364) |
| AGS-22-200 | 7.87 (200) | 18.28 (464) |
| AGS-22-250 | 9.84 (250) | 22.20 (564) |
| AGS-22-300 | 11.81 (300) | 26.14 (664) |
| AGS-22-350 | 13.78 (350) | 30.08 (764) |
| AGS-22-400 | 15.75 (400) | 34.02 (864) |

Ordering Example **AGS-22-150-AE-V-800**

Model (Push Type) _____

Body \varnothing 0.91" (23 mm) _____

Stroke 5.91" (150 mm) _____

Piston Rod End Fitting A _____

Body End Fitting E _____

Adjustable (V) _____

Nominal Force F_1 180 lbs (800 N) _____

The end fittings are interchangeable.

*G Angle Ball Joint has 5/16-18 Imperial Thread

| Alternate Stroke Lengths Available, Consult Factory | | |
|---|-----------------------|-----------------------------|
| Model | Stroke inches (mm) | L - extended inches (mm) |
| GS-22-50 | 1.97 (50) | 6.46 (164) |
| GS-22-450 | 17.72 (450) | 37.95 (964) |
| GS-22-500 | 19.69 (500) | 41.89 (1,064) |
| GS-22-550 | 21.65 (550) | 45.83 (1,164) |
| GS-22-600 | 23.62 (600) | 49.76 (1,264) |
| GS-22-650 | 25.59 (650) | 53.70 (1,364) |
| GS-22-700 | 27.56 (700) | 57.64 (1,464) |

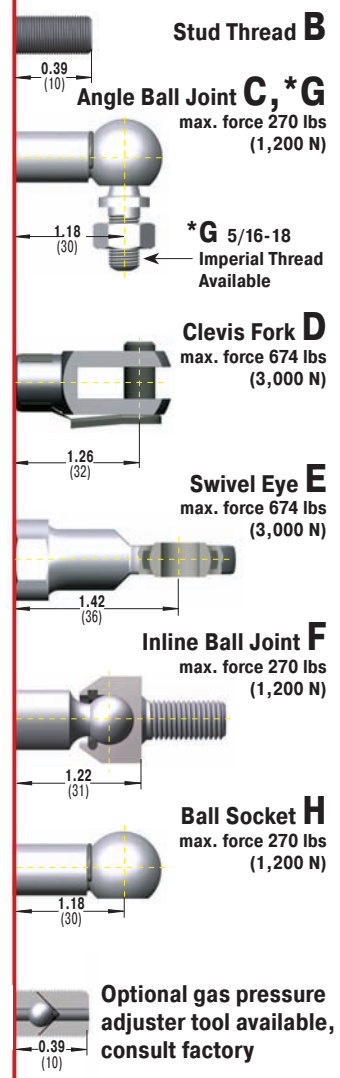
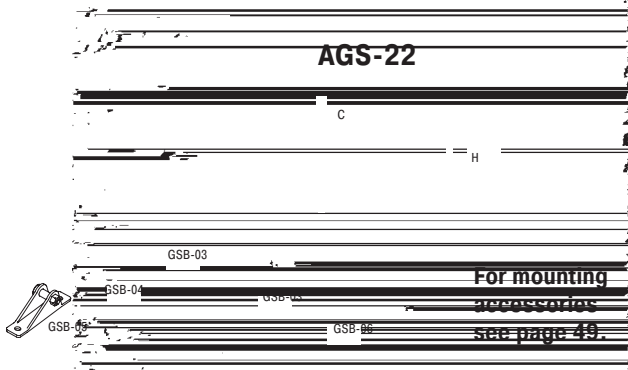
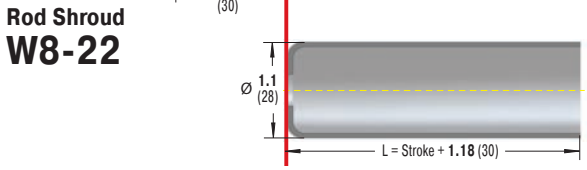

Technical Data

- On request:** Without damping, special damping, special lengths, strokes and alternative end fittings.
- Available force range F_1 at 68 °F (20 °C):** 18 lbs to 292 lbs (80 N to 1,300 N)
- Mounting:** In any position
- Advice:** We recommend mounting with piston rod downwards to take advantage of the built-in end position damping.
- AGS end position damping length:** Approx. 0.20" (5 mm)
- GS end position damping length:** Strong end position damping approx. 0.79" to 2.76" (20 to 70 mm) – depending on the stroke – and slow extension speed.
- Material:** Body: Black coated steel. Piston rod: Steel, wear-resistant. GS models have chrome rods. End fittings: Zinc plated steel.
- AGS force progression:** Approx. 50% to 56%
- GS force progression:** Approx. 39% to 50%

End Fitting

Standard Dimensions – inches and (mm)

End Fitting

Dimensions

| Model | Stroke inches (mm) | L - extended inches (mm) |
|------------|-----------------------|-----------------------------|
| AGS-28-100 | 3.94 (100) | 10.31 (262) |
| AGS-28-150 | 5.91 (150) | 14.25 (362) |
| AGS-28-200 | 7.87 (200) | 18.19 (462) |
| AGS-28-250 | 9.84 (250) | 22.13 (562) |
| AGS-28-300 | 11.81 (300) | 26.06 (662) |
| AGS-28-350 | 13.78 (350) | 30.00 (762) |
| AGS-28-400 | 15.75 (400) | 33.94 (862) |
| AGS-28-450 | 17.72 (450) | 37.87 (962) |
| AGS-28-500 | 19.69 (500) | 41.81 (1,062) |
| AGS-28-550 | 21.65 (550) | 45.75 (1,162) |
| AGS-28-600 | 23.62 (600) | 49.69 (1,262) |

Ordering Example **AGS-28-150-EE-V-1200**

Model (Push Type) _____
 Body \varnothing 1.1" (28 mm) _____
 Stroke 5.91" (150 mm) _____
 Piston Rod End Fitting E _____
 Body End Fitting E _____
 Adjustable (V) _____
 Nominal Force F_1 270 lbs (1,200 N) _____

The end fittings are interchangeable.

Alternate Stroke Lengths Available, Consult Factory

| Model | Stroke inches (mm) | L - extended inches (mm) |
|-----------|-----------------------|-----------------------------|
| GS-28-650 | 25.59 (650) | 53.62 (1,362) |
| GS-28-700 | 27.56 (700) | 57.56 (1,462) |
| GS-28-750 | 29.53 (750) | 61.50 (1,562) |

End Fitting A
max. force 2,248 lbs (10,000 N)

Stud Thread B

Angle Ball Joint C
max. force 405 lbs (1,800 N)

Clevis Fork D
max. force 2,248 lbs (10,000 N)

Swivel Eye E
max. force 2,248 lbs (10,000 N)

Inline Ball Joint F
max. force 405 lbs (1,800 N)

Optional gas pressure adjuster tool available, consult factory

Rod Shroud W10-28
 \varnothing 1.26 (32)
L = Stroke + 1.57 (40)

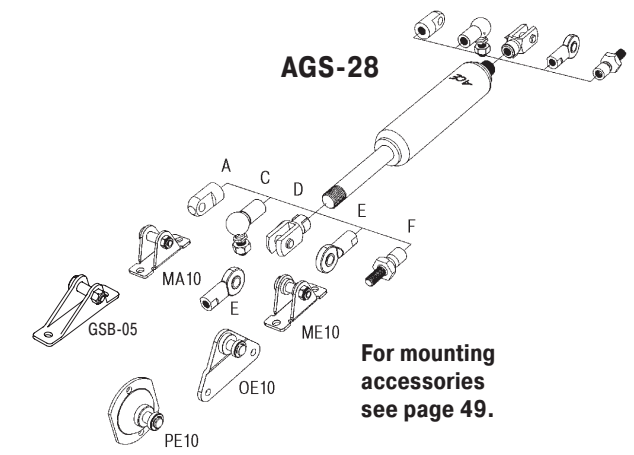

Technical Data

On request: Without damping, special damping, special lengths, strokes and alternative end fittings.

Available force range F_1 at 68 °F (20 °C): 22 lbs to 562 lbs (100 N to 2,500 N)

Mounting: In any position

Advice: We recommend mounting with piston rod downwards to take advantage of the built-in end position damping.

AGS end position damping length: Approx. 0.20" (5 mm)

GS end position damping length: Strong end position damping approx. 1.18" to 2.76" (30 to 70 mm) – depending on the stroke – and slow extension speed.

Material: Body: Black coated steel. Piston rod: Steel, wear-resistant. GS models have chrome rods. End fittings: Zinc plated steel.

AGS force progression: Approx. 48% to 52%

GS force progression: Approx. 60% to 95%

End Fitting

Standard Dimensions – inches and (mm)

End Fitting

Dimensions

| Model | Stroke inches (mm) | L - extended inches (mm) |
|------------|-----------------------|-----------------------------|
| GS-40-100 | 3.94 (100) | 12.48 (317) |
| GS-40-150 | 5.91 (150) | 16.42 (417) |
| GS-40-200 | 7.87 (200) | 20.35 (517) |
| GS-40-300 | 11.81 (300) | 28.23 (717) |
| GS-40-400 | 15.75 (400) | 36.10 (917) |
| GS-40-500 | 19.69 (500) | 43.98 (1,117) |
| GS-40-600 | 23.62 (600) | 51.85 (1,317) |
| GS-40-800 | 31.50 (800) | 67.60 (1,717) |
| GS-40-1000 | 39.37 (1,000) | 83.35 (2,117) |

Ordering Example
AGS-40-150-DD-3500
 Model (Push Type) _____
 Body Ø 1.57 (40 mm) _____
 Stroke 5.91 (150 mm) _____
 Piston Rod End Fitting D14 _____
 Body End Fitting D14 _____
 Nominal Force F₁ 787 lbs (3,500 N) _____

The end fittings are interchangeable.

End Fitting A
max. force 2,248 lbs (10,000 N)

Stud Thread B
M14x1.5

Angle Ball Joint C
max. force 674 lbs (3,000 N)

Clevis Fork D
max. force 2,248 lbs (10,000 N)

Swivel Eye E
max. force 2,248 lbs (10,000 N)

Inline Ball Joint F
max. force 719 lbs (3,200 N)

Adjuster Knob U14
See page 58.

Rod Shroud W14-40
L = Stroke + 1.57 (40)

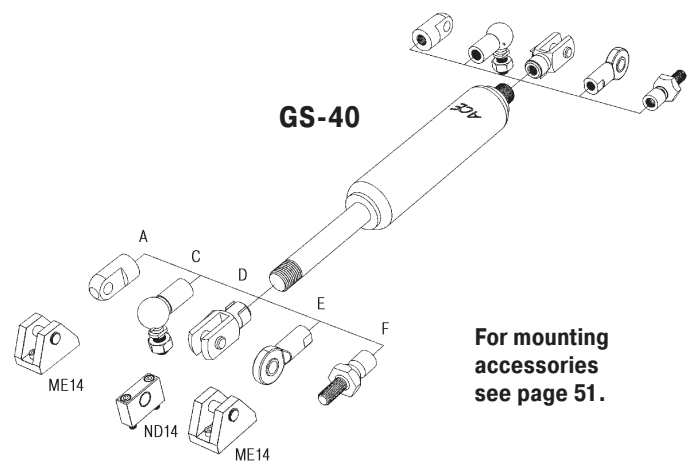

Technical Data

On request: Without damping, standard length damping, special force curves, special lengths, alternative end fittings, wiper, stainless steel (see pages 27 & 32).

Available force range F₁ at 68 °F (20 °C): 112 lbs to 1,124 lbs (500 N to 5,000 N)

Mounting: In any position

Advice: We recommend mounting with piston rod downwards to take advantage of the built-in end position damping.

End position damping length: Strong end position damping approx. 1.18" to 2.76" (30 to 70 mm) – depending on the stroke – and slow extension speed.

Material: Body: Black coated steel. Piston rod: With wear-resistant coating. End fittings: Zinc plated steel.

Progression: Approx. 47% to 53%, F₂ max. 1,720 lbs (7,650 N)

End Fitting

Standard Dimensions – inches and (mm)

End Fitting

B24 Stud Thread **B24**

D24 Clevis Fork **D24**
max. force 11,240 lbs (50,000 N)

E24 Swivel Eye **E24**
max. force 11,240 lbs (50,000 N)

Dimensions

| Model | Stroke inches (mm) | L - extended inches (mm) |
|-----------|-----------------------|-----------------------------|
| GS-70-100 | 3.94 (100) | 12.60 (320) |
| GS-70-200 | 7.87 (200) | 20.47 (520) |
| GS-70-300 | 11.81 (300) | 28.35 (720) |
| GS-70-400 | 15.75 (400) | 36.22 (920) |
| GS-70-500 | 19.69 (500) | 44.09 (1,120) |
| GS-70-600 | 23.62 (600) | 51.97 (1,320) |
| GS-70-700 | 27.56 (700) | 59.84 (1,520) |
| GS-70-800 | 31.50 (800) | 67.72 (1,720) |

Ordering Example **AGS-70-200-EE-8000**

Model (Push Type) _____
 Body Ø 2.76 (70 mm) _____
 Stroke 7.87 (200 mm) _____
 Piston Rod End Fitting E24 _____
 Body End Fitting E24 _____
 Nominal Force F₁ 1,798 lbs (8,000 N) _____

The end fittings are interchangeable.
Standard gas spring with valve.

Rod Shroud W24-70

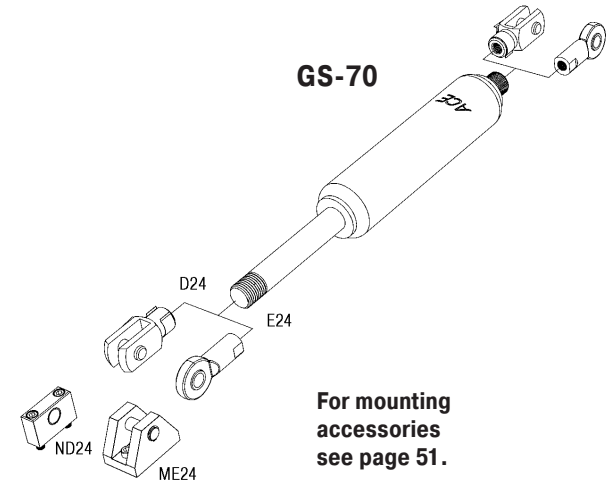

Technical Data

On request: Without damping, extended length damping, special force curves, special lengths, alternative end fittings, wiper, stainless steel.

Available force range F₁ at 68 °F (20 °C): 450 lbs to 2,923 lbs (2,000 N to 13,000 N)

Mounting: In any position

Advice: We recommend mounting with piston rod downwards to take advantage of the built-in end position damping.

End position damping length: Approx. 0.39" (10 mm)

Material: Body: Black coated steel or zinc plated steel. Piston rod: Hard chrome plated. End fittings: Zinc plated steel.

Progression: Approx. 25%, F₂ max. 3,653 lbs (16,250 N)

ACE offers **tandem gas springs** specially for heavy flaps and hoods with a large opening angle. These are characterised by a high initial force and low end force. The tandem gas springs have two pressure tubes with different extension forces and progression curves, and are therefore able to cover two force ranges. **The tandem gas springs are designed specifically for your application.** The force ranges are matched exactly to each other and adjusted to the required application dynamics. Tandem gas springs are maintenance-free and ready to install. The comprehensive range of fitting parts ensures easy installation.

"Reduce the need for muscle power for comfortably opening heavy flaps!"



NEW

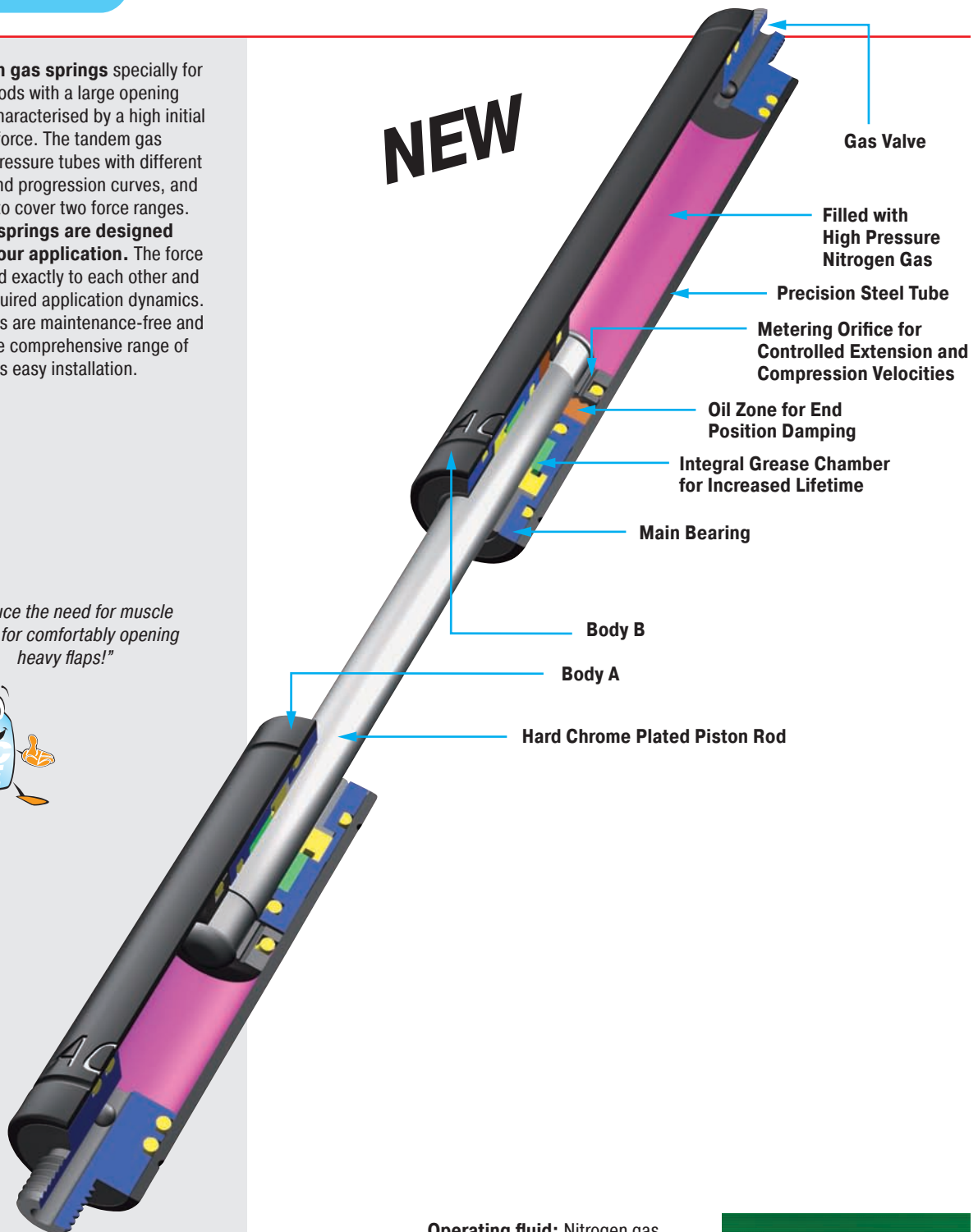

Operating fluid: Nitrogen gas and oil

Material: Piston rod: Hard chrome plated steel. Bodies and end fittings: Zinc plated steel.

Mounting: According to calculation. Please adopt the mounting points determined by ACE.

Operating temperature range: -4 °F to 176 °F (-20 °C to 80 °C)

On request: Material 1.4301/1.4305, AISI 304/303 (V2A) and material 1.4404/1.4571, AISI 316L/316Ti (V4A).



End Fitting

Standard Dimensions – inches and (mm)

End Fitting

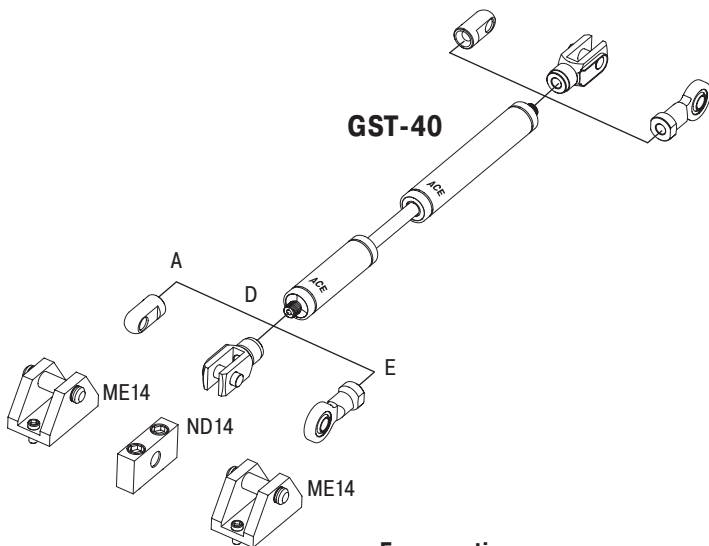
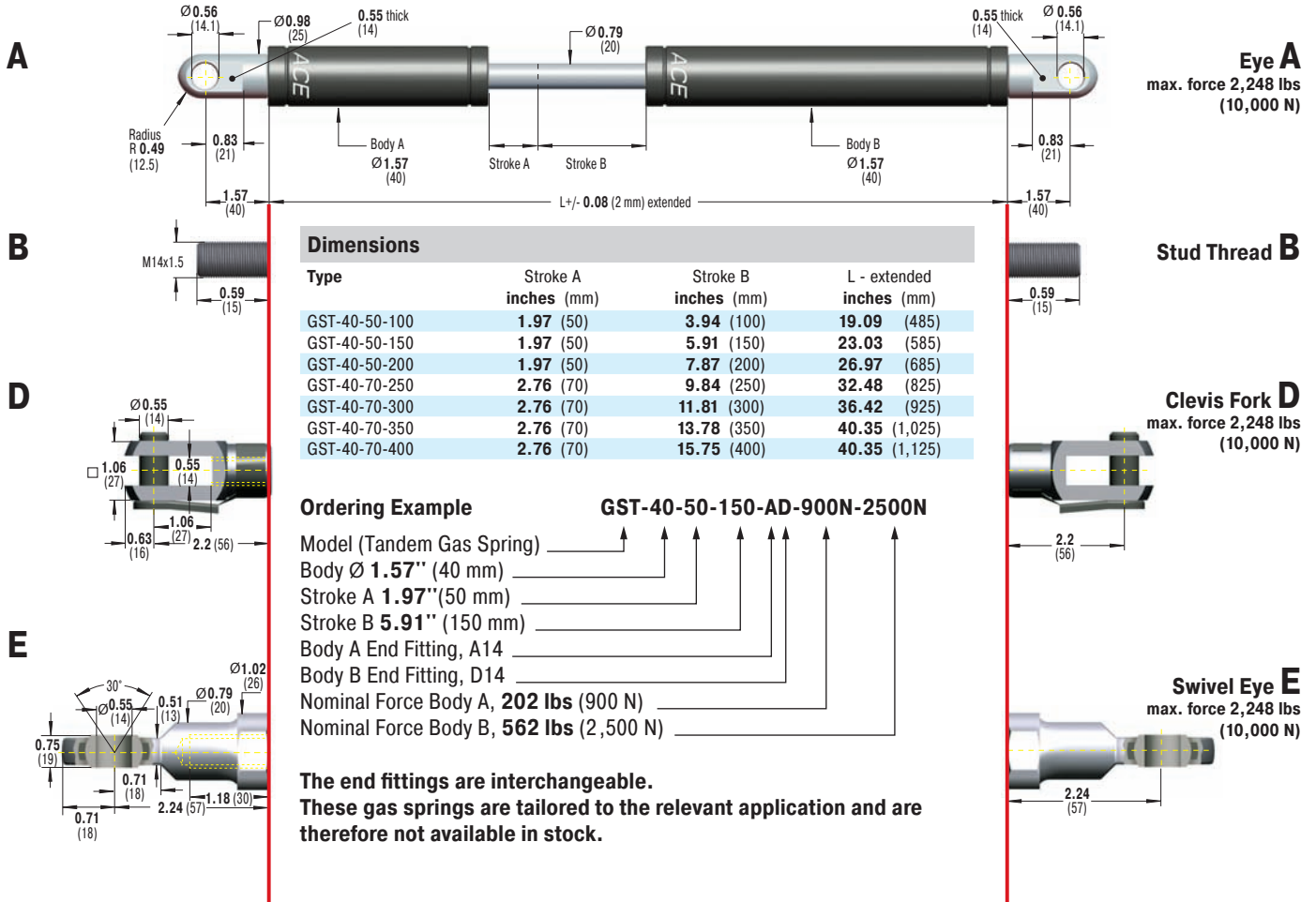

For mounting accessories see page 51.

Technical Data

On request: Without damping, standard length damping, special force curves, special lengths, alternative end fittings, wiper.

Available force range F_1 at 68 °F (20 °C): 67 lbs to 1,124 lbs (300 N to 5,000 N)

Mounting: According to calculation. Please adopt the mounting points determined by ACE.

End position damping length: Strong end position damping approx. 1.18" to 2.76" (30 to 70 mm) – depending on the stroke – and slow extension speed.

Material: Piston rod: Hard chrome plated. Bodies and accessories: Zinc plated steel.

Progression: According to calculation relating to your application.

Stainless steel gas springs (push type)
 Material 1.4301/1.4305, AISI 304/303 (V2A),
 Material 1.4404/1.4571, AISI 316L/316Ti (V4A)

In addition to the comprehensive range of industrial gas springs with valve, ACE also offers a wide range of industrial gas springs made of stainless steel with body diameters from .31" to 2.76" (8 mm to 70 mm). This high-quality version is also available on request in all stroke lengths and possible extension forces. The comprehensive range of fitting parts ensures easy installation and makes the gas springs universal in use. Stainless steel industrial gas springs are used everywhere that raising and lowering is required. Due to their special properties, **non-rusting and low magnetism**, they are the preferred equipment for medical and clean-room technology, the foodstuffs industry, electronics and shipbuilding sector.

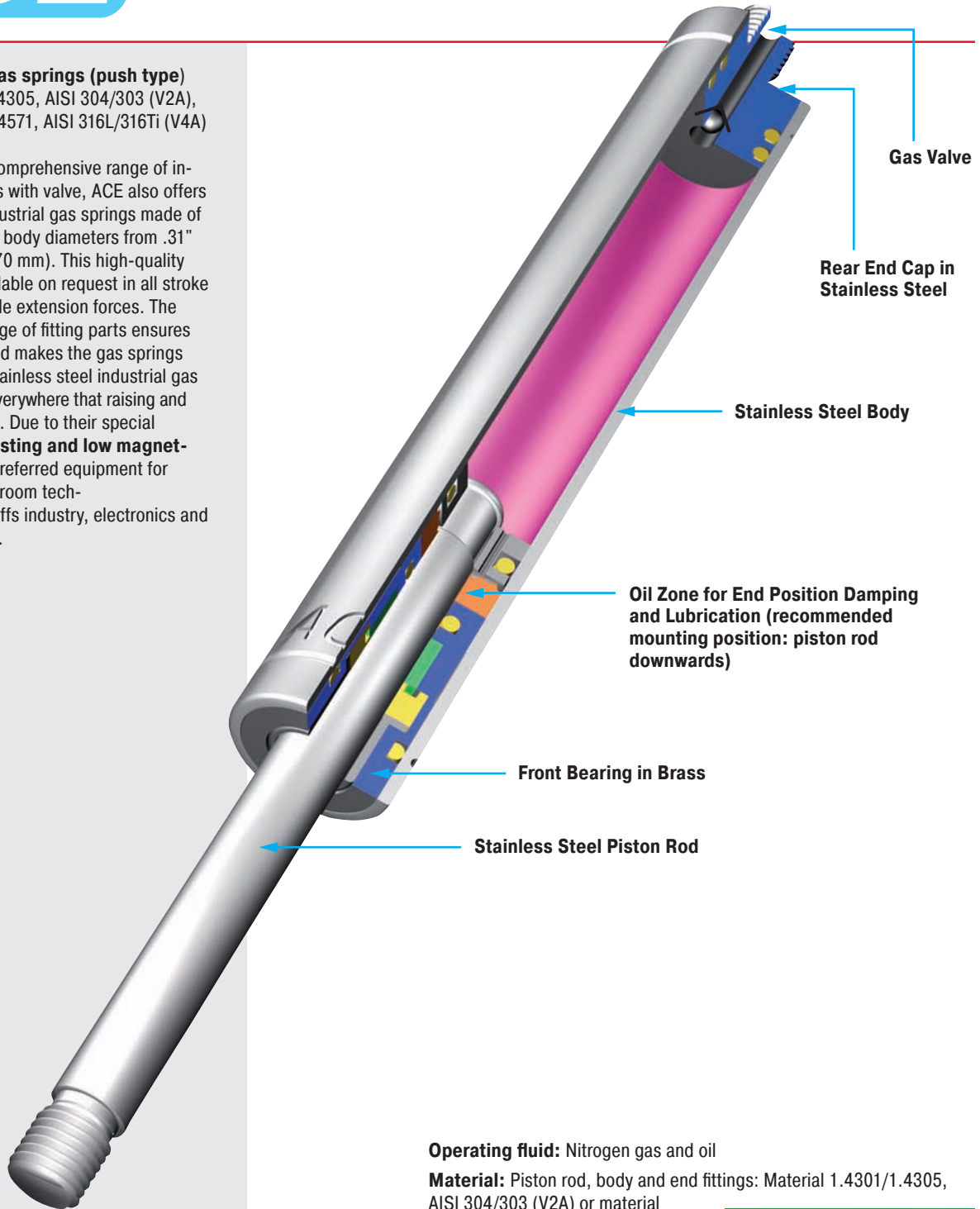

Operating fluid: Nitrogen gas and oil

Material: Piston rod, body and end fittings: Material 1.4301/1.4305, AISI 304/303 (V2A) or material 1.4404/1.4571, AISI 316L/316Ti (V4A).

Mounting: In any position

Advice: We recommend mounting with piston rod downwards to take advantage of the built-in end position damping.

Operating temperature range:
 -4 °F to 176 F (-20 °C to 80 °C)

On request: Without damping, strong end position damping, special force curves, wiper, special lengths, alternative end fittings.





Stainless Steel Gas Springs GS-8-V4A (Push Type)

Extension Forces 6 lbs to 22 lbs (25 N to 100 N)
[when Piston Rod Compressed up to 29 lbs (130 N)]

End Fitting

Standard Dimensions – inches and (mm)

End Fitting

B3,5

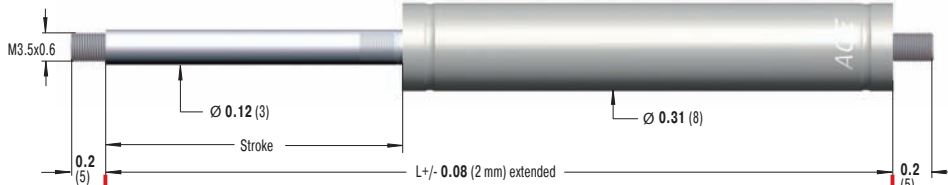

Stud Thread **B3,5**

A3,5-V4A

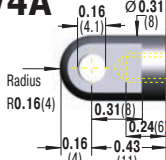

Dimensions

| Model | Stroke inches (mm) | L - extended inches (mm) |
|-------------|-----------------------|-----------------------------|
| GS-8-20-V4A | 0.79 (20) | 2.83 (72) |
| GS-8-30-V4A | 1.18 (30) | 3.62 (92) |
| GS-8-40-V4A | 1.57 (40) | 4.41 (112) |
| GS-8-50-V4A | 1.97 (50) | 5.20 (132) |
| GS-8-60-V4A | 2.36 (60) | 5.98 (152) |
| GS-8-80-V4A | 3.14 (80) | 7.56 (192) |

Eye
A3,5-V4A
max. force 83 lbs
(370 N)

C3,5-V4A

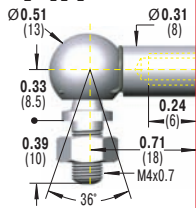

Angle Ball Joint
C3,5-V4A
max. force 83 lbs
(370 N)

D3,5-V4A

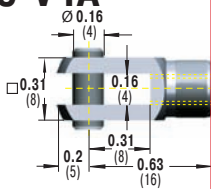

Clevis Fork
D3,5-V4A
max. force 83 lbs
(370 N)

G3,5-V4A

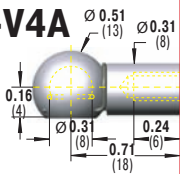

Ball Socket
G3,5-V4A
max. force 83 lbs
(370 N)

Rod Shroud
W3,5-8-V4A

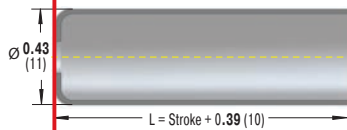

Adjuster Knob **U3,5**
See page 58.

Ordering Example

Model (Push Type) _____
 Body Ø **0.31"** (8 mm) _____
 Stroke **1.18"** (30 mm) _____
 Piston Rod End Fitting **A3,5-V4A** _____
 Body End Fitting **C3,5-V4A** _____
 Nominal Force **F₁ 7 lbs** (30 N) _____
 Indicated by K.-No. on delivery _____

GS-8-30-AC-30-V4A

The end fittings are interchangeable.

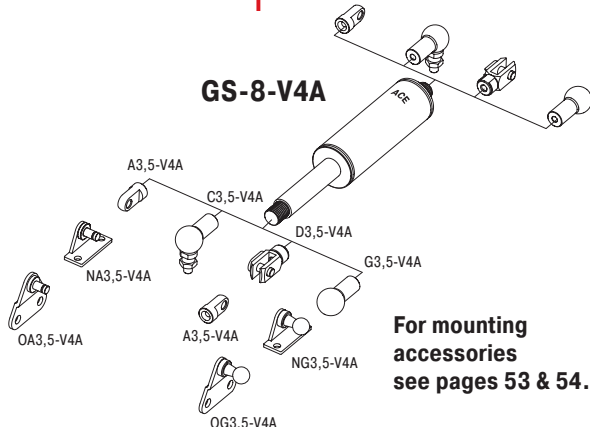

For mounting accessories see pages 53 & 54.

Technical Data

On request: Without damping, increased end position damping, special force curves, special end fittings.

Available force range F₁ at 68 °F (20 °C): 6 lbs to 22 lbs (25 N to 100 N)

Mounting: In any position

Advice: We recommend mounting with piston rod downwards to take advantage of the built-in end position damping.

End position damping length: approx. 0.2" (5 mm)

Material: Piston rod, body and end fittings: Material 1.4404/1.4571, AISI 316L/316Ti (V4A).

Progression: approx. 27%, F₂ max. 29 lbs (130 N)



Extension Forces 7 lbs to 22 lbs (30 N to 100 N)
[when Piston Rod Compressed up to 26 lbs (115 N)]

End Fitting

Standard Dimensions – inches and (mm)

End Fitting

B3,5

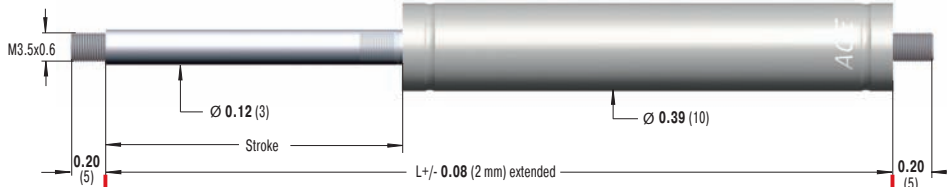

Stud Thread B3,5

A3,5-V4A

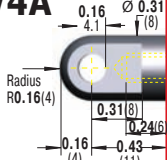

Eye
A3,5-V4A
max. force 83 lbs
(370 N)

C3,5-V4A

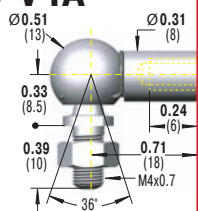

Angle Ball Joint
C3,5-V4A
max. force 83 lbs
(370 N)

D3,5-V4A

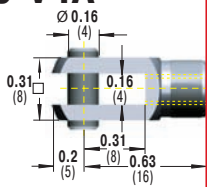

Clevis Fork
D3,5-V4A
max. force 83 lbs
(370 N)

G3,5-V4A

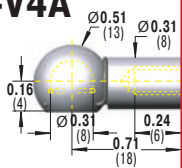

Ball Socket
G3,5-V4A
max. force 83 lbs
(370 N)

Rod Shroud

W3,5-10-V4A

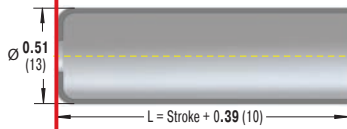

| Dimensions | | |
|--------------|-----------------------|-----------------------------|
| Model | Stroke inches (mm) | L - extended inches (mm) |
| GS-10-20-V4A | 0.79 (20) | 2.83 (72) |
| GS-10-30-V4A | 1.18 (30) | 3.62 (92) |
| GS-10-40-V4A | 1.57 (40) | 4.41 (112) |
| GS-10-50-V4A | 1.97 (50) | 5.20 (132) |
| GS-10-60-V4A | 2.36 (60) | 5.98 (152) |
| GS-10-80-V4A | 3.14 (80) | 7.56 (192) |

Ordering Example

Model (Push Type) _____
 Body Ø 0.39" (10 mm) _____
 Stroke 1.18" (30 mm) _____
 Piston Rod End Fitting A3,5-V4A _____
 Body End Fitting C3,5-V4A _____
 Nominal Force F₁ 7 lbs (30 N) _____
 Indicated by K.-No. on delivery _____

GS-10-30-AC-30-V4A

The end fittings are interchangeable.

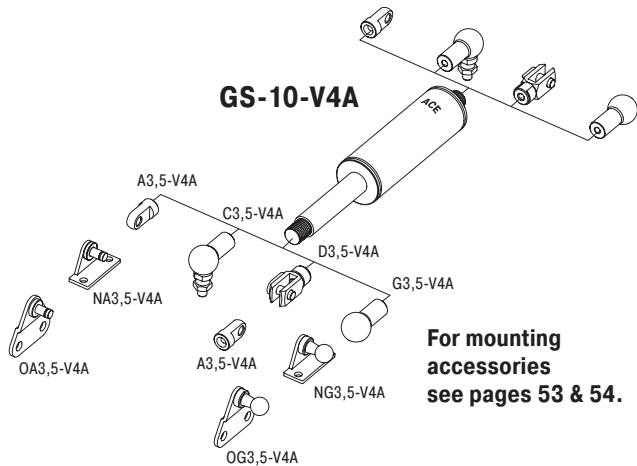

For mounting accessories see pages 53 & 54.

Technical Data

On request: Without damping, increased end position damping, special force curves, special end fittings.

Available force range F₁ at 68 °F (20 °C): 7 lbs to 22 lbs (30 N to 100 N)

Mounting: In any position

Advice: We recommend mounting with piston rod downwards to take advantage of the built-in end position damping.

End position damping length: approx. 0.2" (5 mm)

Material: Piston rod, body and end fittings: Material 1.4404/1.4571, AISI 316L/316Ti (V4A).

Progression: approx. 12%, F₂ max. 26 lbs (115 N)

Adjuster Knob U3,5
See page 58.

End Fitting

Standard Dimensions – inches and (mm)

End Fitting

B3,5

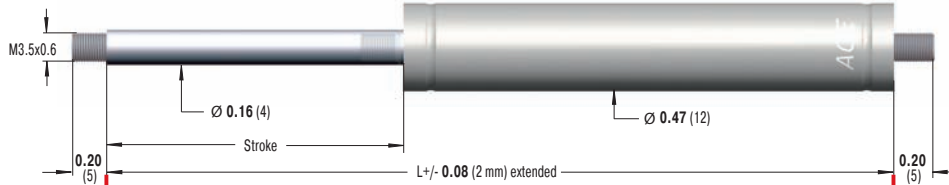

Stud Thread **B3,5**

A3,5-V4A

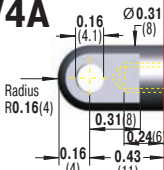

Dimensions

| Model | Stroke inches (mm) | L - extended inches (mm) |
|---------------|-----------------------|-----------------------------|
| GS-12-20-V4A | 0.79 (20) | 2.83 (72) |
| GS-12-30-V4A | 1.18 (30) | 3.62 (92) |
| GS-12-40-V4A | 1.57 (40) | 4.41 (112) |
| GS-12-50-V4A | 1.97 (50) | 5.20 (132) |
| GS-12-60-V4A | 2.36 (60) | 5.98 (152) |
| GS-12-80-V4A | 3.14 (80) | 7.56 (192) |
| GS-12-100-V4A | 3.94 (100) | 9.13 (192) |
| GS-12-120-V4A | 4.72 (120) | 10.71 (192) |
| GS-12-150-V4A | 5.91 (150) | 13.07 (332) |

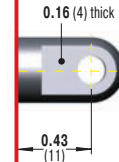

Eye
A3,5-V4A
max. force 83 lbs
(370 N)

C3,5-V4A

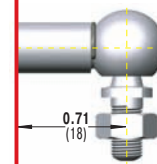
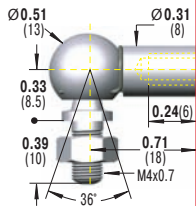

Angle Ball Joint
C3,5-V4A
max. force 83 lbs
(370 N)

D3,5-V4A

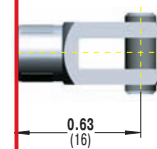
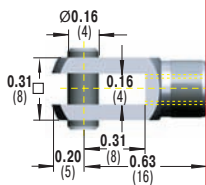

Clevis Fork
D3,5-V4A
max. force 83 lbs
(370 N)

Ordering Example

Model (Push Type) _____
Body Ø **0.47"** (12 mm) _____
Stroke **3.94** (100 mm) _____
Piston Rod End Fitting A3,5-V4A _____
Body End Fitting A3,5-V4A _____
Nominal Force F₁ **7 lbs** (30 N) _____
Indicated by K.-No. on delivery _____

GS-12-100-AA-30-V4A

The end fittings are interchangeable.

G3,5-V4A

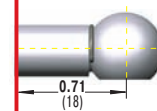
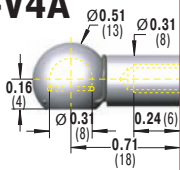

Ball Socket
G3,5-V4A
max. force 83 lbs
(370 N)

Rod Shroud
W3,5-12-V4A

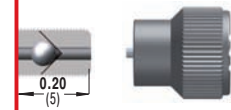
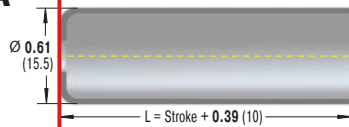

Adjuster Knob **U3,5**
See page 58.

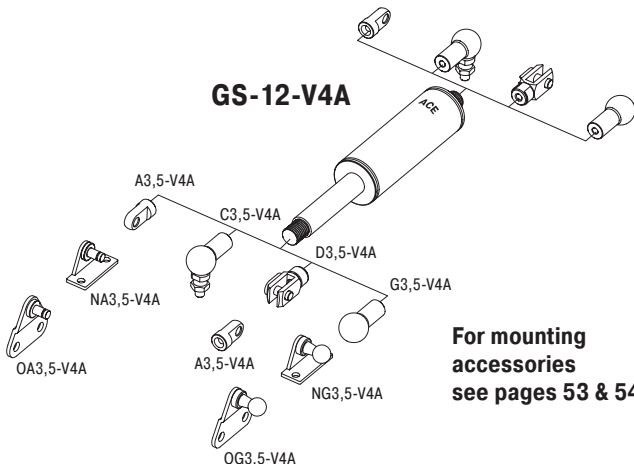

For mounting accessories see pages 53 & 54.

Technical Data

On request: Without damping, increased end position damping, special force curves, special end fittings.

Available force range F₁ at 68 °F (20 °C): 6 lbs to 45 lbs (25 N to 200 N)

Mounting: In any position

Advice: We recommend mounting with piston rod downwards to take advantage of the built-in end position damping.

End position damping length: approx. 0.39" (10 mm)

Material: Piston rod, body and end fittings: Material 1.4404/1.4571, AISI 316L/316Ti (V4A).

Progression: approx. 18 %, F₂ max. 53 lbs (235 N)

Extension Forces 9 lbs to 90 lbs (40 N to 400 N)
[when Piston Rod Compressed up to 110 lbs (490 N)]

End Fitting

Standard Dimensions – inches and (mm)

End Fitting

B5

A5-V4A

C5-V4A

D5-V4A

E5-V4A

G5-V4A

Rod Shroud W5-15-V4A

| Dimensions | | |
|---------------|-----------------------|-----------------------------|
| Type | Stroke inches (mm) | L - extended inches (mm) |
| GS-15-20-V4A | 0.79 (20) | 2.91 (74) |
| GS-15-40-V4A | 1.57 (40) | 4.49 (114) |
| GS-15-50-V4A | 1.97 (50) | 5.28 (134) |
| GS-15-60-V4A | 2.36 (60) | 6.06 (154) |
| GS-15-80-V4A | 3.15 (80) | 7.64 (194) |
| GS-15-100-V4A | 3.94 (100) | 9.21 (234) |
| GS-15-120-V4A | 4.72 (120) | 10.79 (274) |
| GS-15-150-V4A | 5.91 (150) | 13.15 (334) |

Ordering Example

Type (Push Type) _____

Body Ø 0.61" (15.6 mm) _____

Stroke 5.91" (150 mm) _____

Piston Rod End Fitting A5-V4A _____

Body End Fitting C5-V4A _____

Nominal Force F₁ 34 lbs (150 N) _____

Indicated by K.-No. on delivery _____

GS-15-150-AC-150-V4A

The end fittings are interchangeable.
Strokes also available up to 11.81" (300 mm).

Stud Thread B5

Eye A5-V4A
max. force 110 lbs (490 N)

Angle Ball Joint C5-V4A
max. force 97 lbs (430 N)

Clevis Fork D5-V4A
max. force 110 lbs (490 N)

Swivel Eye E5-V4A
max. force 110 lbs (490 N)

Ball Socket G5-V4A
max. force 97 lbs (430 N)

Adjuster Knob U5
See page 58.

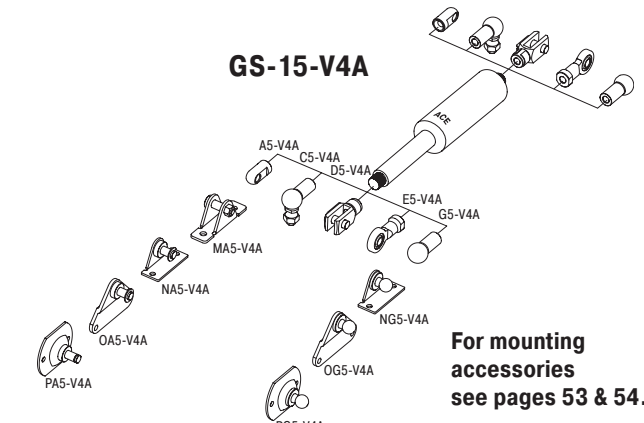

Technical Data

- On request:** Without damping, increased end position damping, special force curves, special lengths, alternative end fittings and wiper.
- Available force range F₁ at 68 °F (20 °C):** 9 lbs to 90 lbs (40 N to 400 N)
- Mounting:** In any position
- Advice:** We recommend mounting with piston rod downwards to take advantage of the built-in end position damping.
- End position damping length:** Approx. 0.79" (20 mm) depending on the stroke
- Material:** Piston rod, body and end fittings: AISI 316L/316Ti (V4A).
- Progression:** Approx. 34%, F₂ max. 110 lbs (490 N)

Extension Forces 11 lbs to 157 lbs (50 N to 700 N)
[when Piston Rod Compressed up to 205 lbs (910 N)]

End Fitting

Standard Dimensions – inches and (mm)

End Fitting

B8

A8-V4A

C8-V4A

D8-V4A

E8-V4A

G8-V4A

Rod Shroud W8-19-V4A

Dimensions

| Model | Stroke inches (mm) | L - extended inches (mm) |
|---------------|-----------------------|-----------------------------|
| GS-19-50-V4A | 1.97 (50) | 6.46 (164) |
| GS-19-100-V4A | 3.94 (100) | 10.39 (264) |
| GS-19-150-V4A | 5.91 (150) | 14.33 (364) |
| GS-19-200-V4A | 7.87 (200) | 18.27 (464) |
| GS-19-250-V4A | 9.84 (250) | 22.20 (564) |
| GS-19-300-V4A | 11.81 (300) | 26.14 (664) |

Ordering Example

Model (Push Type) _____

Body Ø 0.75" (19 mm) _____

Stroke 5.91" (150 mm) _____

Piston Rod End Fitting A8-V4A _____

Body End Fitting C8-V4A _____

Nominal Force F₁ 135 lbs (600 N) _____

Indicated by K.-No. on delivery _____

GS-19-150-AC-600-V4A

The end fittings are interchangeable.
Strokes also available up to 19.69" (500 mm).

Stud Thread B8

Eye A8-V4A
max. force 351 lbs (1,560 N)

Angle Ball Joint C8-V4A
max. force 256 lbs (1,140 N)

Clevis Fork D8-V4A
max. force 351 lbs (1,560 N)

Swivel Eye E8-V4A
max. force 351 lbs (1,560 N)

Ball Socket G8-V4A
max. force 256 lbs (1,140 N)

Adjuster Knob U8
See page 58.

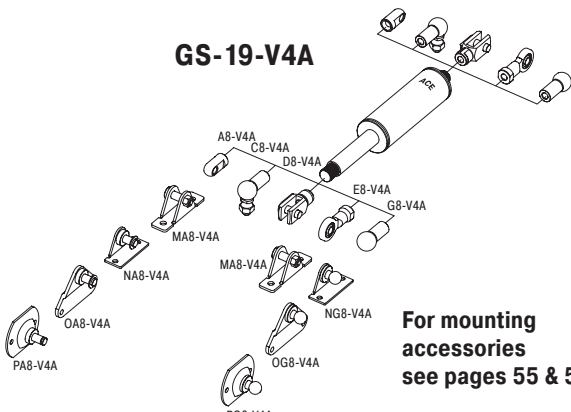

Technical Data

On request: Without damping, increased end position damping, special force curves, special lengths, alternative end fittings and wiper.

Available force range F₁ at 68 °F (20 °C): 11 lbs to 157 lbs (50 N to 700 N)

Mounting: In any position

Advice: We recommend mounting with piston rod downwards to take advantage of the built-in end position damping.

End position damping length: Approx. 0.79" (20 mm) depending on the stroke

Material: Piston rod, body and end fittings: AISI 316L/316Ti (V4A).

Progression: Approx. 33%, F₂ max. 205 lbs (910 N)

Extension Forces 22 lbs to 270 lbs (100 N to 1,200 N)
 [when Piston Rod Compressed up to 351 lbs (1,560 N)]

End Fitting

Standard Dimensions – inches and (mm)

End Fitting

| Dimensions | | |
|---------------|-----------------------|-----------------------------|
| Type | Stroke inches (mm) | L - extended inches (mm) |
| GS-22-50-V4A | 1.97 (50) | 6.46 (164) |
| GS-22-100-V4A | 3.94 (100) | 10.39 (264) |
| GS-22-150-V4A | 5.91 (150) | 14.33 (364) |
| GS-22-200-V4A | 7.87 (200) | 18.28 (464) |
| GS-22-250-V4A | 9.84 (250) | 22.20 (564) |
| GS-22-300-V4A | 11.81 (300) | 26.14 (664) |
| GS-22-350-V4A | 13.78 (350) | 30.08 (764) |
| GS-22-400-V4A | 15.75 (400) | 34.02 (864) |
| GS-22-450-V4A | 17.72 (450) | 37.95 (964) |
| GS-22-500-V4A | 19.69 (500) | 41.89 (1,064) |
| GS-22-550-V4A | 21.65 (550) | 45.83 (1,164) |
| GS-22-600-V4A | 23.62 (600) | 49.76 (1,264) |
| GS-22-650-V4A | 25.59 (650) | 53.70 (1,364) |
| GS-22-700-V4A | 27.56 (700) | 57.64 (1,464) |

Ordering Example **GS-22-150-AE-800-V4A**

Type (Push Type) _____
 Body Ø 0.91" (23 mm) _____
 Stroke 5.91" (150 mm) _____
 Piston Rod End Fitting A8-V4A _____
 Body End Fitting E8-V4A _____
 Nominal Force F₁ 180 lbs (800 N) _____
 Indicated by K.-No. on delivery _____

The end fittings are interchangeable.

GS-22-V4A

For mounting accessories see pages 55 & 56.

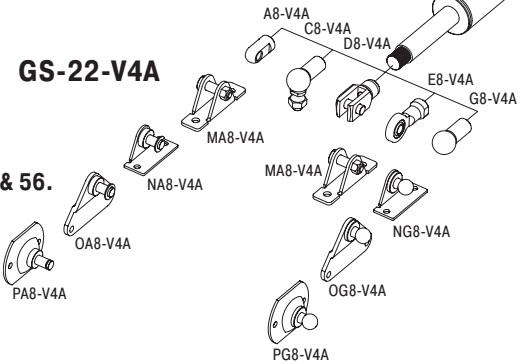

Technical Data

- On request:** Without damping, increased end position damping, special force curves, special lengths, alternative end fittings and wiper.
- Available force range F₁ at 68 °F (20 °C):** 22 lbs to 270 lbs (100 N to 1,200 N)
- Mounting:** In any position
- Advice:** We recommend mounting with piston rod downwards to take advantage of the built-in end position damping.
- End position damping length:** Approx. 0.79" (20 mm) depending on the stroke
- Material:** Piston rod, body and end fittings: AISI 316L/316Ti (V4A).
- Progression:** Approx. 32%, F₂ max. 351 lbs (1,560 N)



Stainless Steel Gas Springs GS-28-V4A (Push Type)

Extension Forces 34 lbs to 562 lbs (150 N to 2,500 N)
 [when Piston Rod Compressed up to 854 lbs (3,800 N)]

End Fitting

Standard Dimensions – inches and (mm)

End Fitting

B10

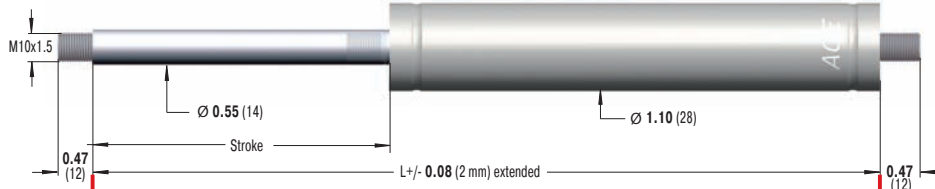

Stud Thread **B10**

A10-V4A

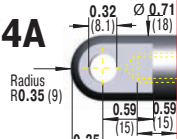

Eye A10-V4A
 max. force 854 lbs (3,800 N)

C10-V4A

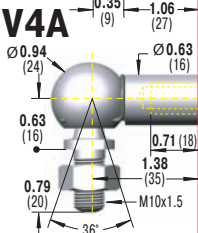

Angle Ball Joint C10-V4A
 max. force 393 lbs (1,750 N)

D10-V4A

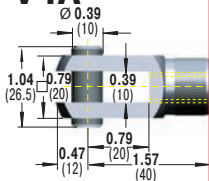

Clevis Fork D10-V4A
 max. force 854 lbs (3,800 N)

E10-V4A

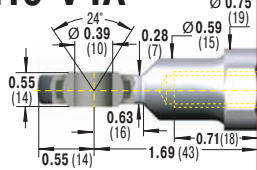

Swivel Eye E10-V4A
 max. force 854 lbs (3,800 N)

Dimensions

| Type | Stroke inches (mm) | L - extended inches (mm) |
|---------------|-----------------------|-----------------------------|
| GS-28-100-V4A | 3.94 (100) | 10.31 (262) |
| GS-28-150-V4A | 5.91 (150) | 14.25 (362) |
| GS-28-200-V4A | 7.87 (200) | 18.19 (462) |
| GS-28-250-V4A | 9.84 (250) | 22.13 (562) |
| GS-28-300-V4A | 11.81 (300) | 26.06 (662) |
| GS-28-350-V4A | 13.78 (350) | 30.00 (762) |
| GS-28-400-V4A | 15.75 (400) | 33.94 (862) |
| GS-28-450-V4A | 17.72 (450) | 37.87 (962) |
| GS-28-500-V4A | 19.69 (500) | 41.81 (1,062) |
| GS-28-550-V4A | 21.65 (550) | 45.75 (1,162) |
| GS-28-600-V4A | 23.62 (600) | 49.69 (1,262) |
| GS-28-650-V4A | 25.59 (650) | 53.62 (1,362) |

Ordering Example

GS-28-150-EE-1200-V4A

Type (Push Type) _____
 Body Ø 1.1" (28 mm) _____
 Stroke 5.91" (150 mm) _____
 Piston Rod End Fitting E10-V4A _____
 Body End Fitting E10-V4A _____
 Nominal Force F₁ 270 lbs (1,200 N) _____
 Indicated by K.-No. on delivery _____

The end fittings are interchangeable.
 Strokes also available up to 29.53" (750 mm).

Rod Shroud

W10-28-V4A

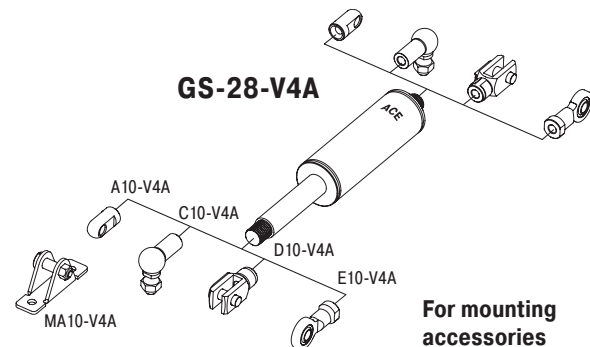
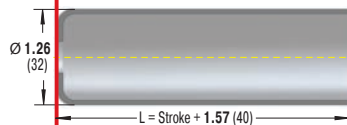

For mounting accessories see pages 55 & 56.

Adjuster Knob U10-VA
 See page 58.

Technical Data

- On request:** Without damping, increased end position damping, special force curves, special lengths, alternative end fittings and wiper.
- Available force range F₁ at 68 °F (20 °C):** 34 lbs to 562 lbs (150 N to 2,500 N)
- Mounting:** In any position
- Advice:** We recommend mounting with piston rod downwards to take advantage of the built-in end position damping.
- End position damping length:** Approx. 0.79" (20 mm) depending on the stroke
- Material:** Piston rod, body and end fittings: AISI 316L/316Ti (V4A).
- Progression:** Approx. 52%, F₂ max. 854 lbs (3,800 N)



Extension Forces 112 lbs to 1,124 lbs (500 N to 5,000 N)
[when Piston Rod Compressed up to 1,574 lbs (7,000 N)]

End Fitting

Standard Dimensions – inches and (mm)

End Fitting

B14

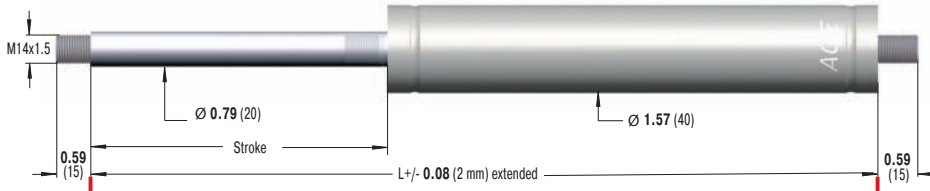

Stud Thread **B14**

A14-V4A

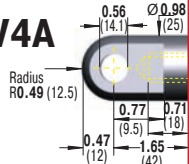

| Dimensions | | |
|---------------|-----------------------|-----------------------------|
| Type | Stroke inches (mm) | L - extended inches (mm) |
| GS-40-100-V4A | 3.94 (100) | 12.48 (317) |
| GS-40-150-V4A | 5.91 (150) | 16.42 (417) |
| GS-40-200-V4A | 7.87 (200) | 20.35 (517) |
| GS-40-300-V4A | 11.81 (300) | 28.23 (717) |
| GS-40-400-V4A | 15.75 (400) | 36.10 (917) |
| GS-40-500-V4A | 19.69 (500) | 43.98 (1,117) |
| GS-40-600-V4A | 23.62 (600) | 51.85 (1,317) |

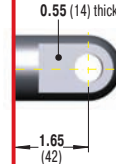

Eye **A14-V4A**
max. force 1,574 lbs (7,000 N)

C14-V4A

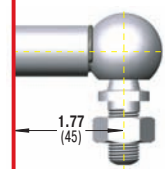
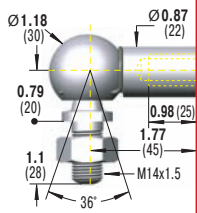

Angle Ball Joint **C14-V4A**
max. force 719 lbs (3,200 N)

D14-V4A

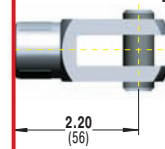
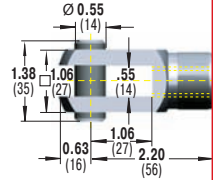

Clevis Fork **D14-V4A**
max. force 1,574 lbs (7,000 N)

E14-V4A

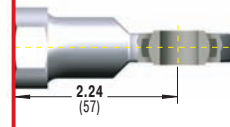
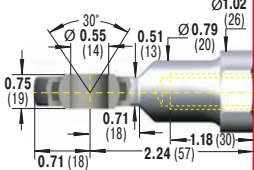

Swivel Eye **E14-V4A**
max. force 1,574 lbs (7,000 N)

Rod Shroud **W14-40-V4A**

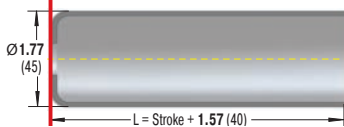

Ordering Example

GS-40-150-DD-3500-V4A

Type (Push Type) _____
 Body Ø 1.57" (40 mm) _____
 Stroke 5.91" (150 mm) _____
 Piston Rod End Fitting D14-V4A _____
 Body End Fitting D14-V4A _____
 Nominal Force F₁ 787 lbs (3,500 N) _____
 Indicated by K.-No. on delivery _____

The end fittings are interchangeable.
Strokes also available up to 39.37" (1,000 mm).

Adjuster Knob **U14-VA**
See page 58.

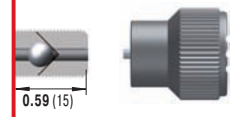

GS-40-V4A

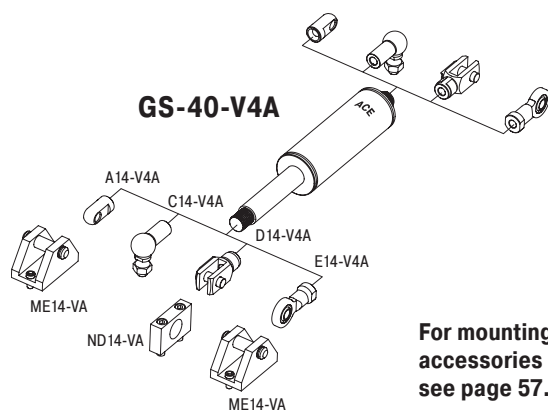

For mounting accessories see page 57.

Technical Data

- On request:** Without damping, increased end position damping, special force curves, special lengths, alternative end fittings and wiper.
- Available force range F₁ at 68 °F (20 °C):** 112 lbs to 1,124 lbs (500 N to 5,000 N)
- Mounting:** In any position
- Advice:** We recommend mounting with piston rod downwards to take advantage of the built-in end position damping.
- End position damping length:** Approx. 2.24" (30 mm) depending on the stroke
- Material:** Piston rod, body and end fittings: AISI 316L/316Ti (V4A).
- Progression:** Approx. 40 %, F₂ max. 1,574 lbs (7,000 N)

Extension Forces 9 lbs to 90 lbs (40 N to 400 N)
[when Piston Rod Compressed up to 110 lbs (490 N)]

End Fitting

Standard Dimensions – inches and (mm)

End Fitting

B5

A5-VA

C5-VA

D5-VA

E5-VA

G5-VA

Rod Shroud W5-15-VA

Dimensions

| Type | Stroke inches (mm) | L - extended inches (mm) |
|--------------|-----------------------|-----------------------------|
| GS-15-20-VA | 0.79 (20) | 2.91 (74) |
| GS-15-40-VA | 1.57 (40) | 4.49 (114) |
| GS-15-50-VA | 1.97 (50) | 5.28 (134) |
| GS-15-60-VA | 2.36 (60) | 6.06 (154) |
| GS-15-80-VA | 3.15 (80) | 7.64 (194) |
| GS-15-100-VA | 3.94 (100) | 9.21 (234) |
| GS-15-120-VA | 4.72 (120) | 10.79 (274) |
| GS-15-150-VA | 5.91 (150) | 13.15 (334) |

Ordering Example

GS-15-150-AC-150-VA

Type (Push Type) _____

Body Ø 0.61" (15.6 mm) _____

Stroke 5.91" (150 mm) _____

Piston Rod End Fitting A5-VA _____

Body End Fitting C5-VA _____

Nominal Force F₁ 34 lbs (150 N) _____

Indicated by K.-No. on delivery _____

The end fittings are interchangeable.
Strokes also available up to 11.81" (300 mm).

Stud Thread B5

Eye A5-VA
max. force 110 lbs (490 N)

Angle Ball Joint C5-VA
max. force 97 lbs (430 N)

Clevis Fork D5-VA
max. force 110 lbs (490 N)

Swivel Eye E5-VA
max. force 110 lbs (490 N)

Ball Socket G5-VA
max. force 97 lbs (430 N)

Adjuster Knob U5
See page 58.

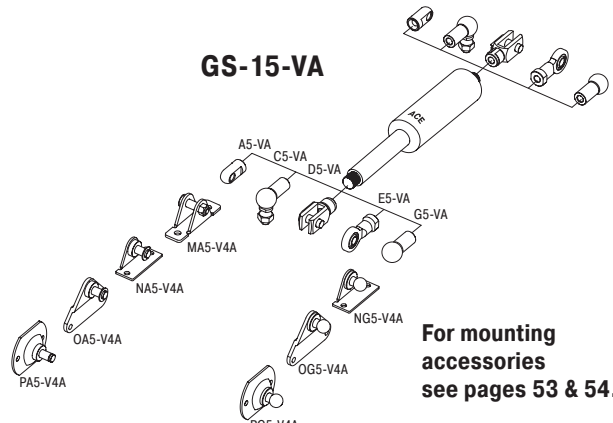

Technical Data

On request: Without damping, increased end position damping, special force curves, special lengths, alternative end fittings, wiper. Gas springs and accessories: Material 1.4404/1.4571, AISI 316L/316Ti (V4A).

Available force range F₁ at 68 °F (20 °C): 9 lbs to 90 lbs (40 N to 400 N)

Mounting: In any position

Advice: We recommend mounting with piston rod downwards to take advantage of the built-in end position damping.

End position damping length: Approx. 0.79" (20 mm) depending on the stroke

Material: Piston rod, body and end fittings: Material 1.4301/1.4305, AISI 304/303 (V2A).

Progression: Approx. 34%, F₂ max. 110 lbs (490 N)

End Fitting

Standard Dimensions – inches and (mm)

End Fitting

B8

A8-VA

C8-VA

D8-VA

E8-VA

G8-VA

Rod Shroud W8-19-VA

Dimensions

| Model | Stroke inches (mm) | L - extended inches (mm) |
|--------------|-----------------------|-----------------------------|
| GS-19-50-VA | 1.97 (50) | 6.46 (164) |
| GS-19-100-VA | 3.94 (100) | 10.39 (264) |
| GS-19-150-VA | 5.91 (150) | 14.33 (364) |
| GS-19-200-VA | 7.87 (200) | 18.27 (464) |
| GS-19-250-VA | 9.84 (250) | 22.20 (564) |
| GS-19-300-VA | 11.81 (300) | 26.14 (664) |

Ordering Example

Model (Push Type) _____

Body Ø 0.75" (19 mm) _____

Stroke 5.91" (150 mm) _____

Piston Rod End Fitting A8-VA _____

Body End Fitting C8-VA _____

Nominal Force F₁ 135 lbs (600 N) _____

Indicated by K.-No. on delivery _____

GS-19-150-AC-600-VA

The end fittings are interchangeable.
Strokes also available up to 19.69" (500 mm).

Stud Thread B8

Eye A8-VA
max. force 351 lbs (1,560 N)

Angle Ball Joint C8-VA
max. force 256 lbs (1,140 N)

Clevis Fork D8-VA
max. force 351 lbs (1,560 N)

Swivel Eye E8-VA
max. force 351 lbs (1,560 N)

Ball Socket G8-VA
max. force 256 lbs (1,140 N)

Adjuster Knob U8
See page 58.

GS-19-VA

For mounting accessories see pages 55 & 56.

Technical Data

On request: Without damping, increased end position damping, special force curves, special lengths, alternative end fittings, wiper. Gas springs and accessories: Material 1.4404/1.4571, AISI 316L/316Ti (V4A).

Available force range F₁ at 68 °F (20 °C): 11 lbs to 157 lbs (50 N to 700 N)

Mounting: In any position

Advice: We recommend mounting with piston rod downwards to take advantage of the built-in end position damping.

End position damping length: Approx. 0.79" (20 mm) depending on the stroke

Material: Piston rod, body and end fittings: Material 1.4301/1.4305, AISI 304/303 (V2A).

Progression: Approx. 33%, F₂ max. 205 lbs (910 N)



Stainless Steel Gas Springs GS-22-VA (Push Type)

Extension Forces 22 lbs to 270 lbs (100 N to 1,200 N)
 [when Piston Rod Compressed up to 351 lbs (1,560 N)]

End Fitting

Standard Dimensions – inches and (mm)

End Fitting

B8

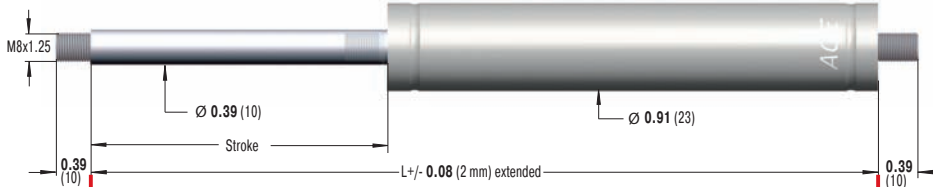

Stud Thread **B8**

A8-VA

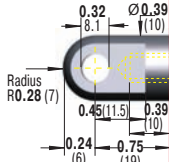

Eye A8-VA
 max. force 351 lbs
 (1,560 N)

C8-VA

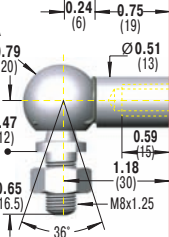

Angle Ball Joint C8-VA
 max. force 256 lbs
 (1,140 N)

D8-VA

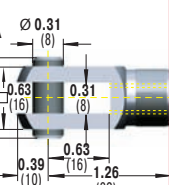

Clevis Fork D8-VA
 max. force 351 lbs
 (1,560 N)

E8-VA

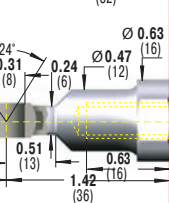

Swivel Eye E8-VA
 max. force 351 lbs
 (1,560 N)

G8-VA

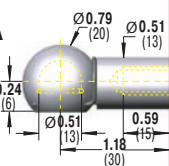

Ball Socket G8-VA
 max. force 256 lbs
 (1,140 N)

Rod Shroud W8-22-VA

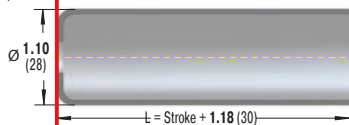

Adjuster Knob U8
 See page 58.

Dimensions

| Type | Stroke inches (mm) | L - extended inches (mm) |
|--------------|-----------------------|-----------------------------|
| GS-22-50-VA | 1.97 (50) | 6.46 (164) |
| GS-22-100-VA | 3.94 (100) | 10.39 (264) |
| GS-22-150-VA | 5.91 (150) | 14.33 (364) |
| GS-22-200-VA | 7.87 (200) | 18.28 (464) |
| GS-22-250-VA | 9.84 (250) | 22.20 (564) |
| GS-22-300-VA | 11.81 (300) | 26.14 (664) |
| GS-22-350-VA | 13.78 (350) | 30.08 (764) |
| GS-22-400-VA | 15.75 (400) | 34.02 (864) |
| GS-22-450-VA | 17.72 (450) | 37.95 (964) |
| GS-22-500-VA | 19.69 (500) | 41.89 (1,064) |
| GS-22-550-VA | 21.65 (550) | 45.83 (1,164) |
| GS-22-600-VA | 23.62 (600) | 49.76 (1,264) |
| GS-22-650-VA | 25.59 (650) | 53.70 (1,364) |
| GS-22-700-VA | 27.56 (700) | 57.64 (1,464) |

Ordering Example

GS-22-150-AE-800-VA

Type (Push Type) _____
 Body Ø 0.91" (23 mm) _____
 Stroke 5.91" (150 mm) _____
 Piston Rod End Fitting A8-VA _____
 Body End Fitting E8-VA _____
 Nominal Force F₁ 180 lbs (800 N) _____
 Indicated by K.-No. on delivery _____

The end fittings are interchangeable.

For mounting accessories see pages 55 & 56.

GS-22-VA

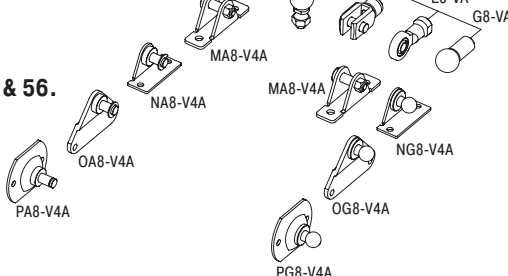

Technical Data

On request: Without damping, increased end position damping, special force curves, special lengths, alternative end fittings, wiper. Gas springs and accessories: Material 1.4404/1.4571, AISI 316L/316Ti (V4A).

Available force range F₁ at 68 °F (20 °C): 22 lbs to 270 lbs (100 N to 1,200 N)

Mounting: In any position

Advice: We recommend mounting with piston rod downwards to take advantage of the built-in end position damping.

End position damping length: Approx. 0.79" (20 mm) depending on the stroke

Material: Piston rod, body and end fittings: Material 1.4301/1.4305, AISI 304/303 (V2A).

Progression: Approx. 32%, F₂ max. 351 lbs (1,560 N)



Extension Forces 34 lbs to 562 lbs (150 N to 2,500 N)
[when Piston Rod Compressed up to 854 lbs (3,800 N)]

End Fitting

Standard Dimensions – inches and (mm)

End Fitting

B10

A10-VA

C10-VA

D10-VA

E10-VA

W10-28-VA

Dimensions

| Type | Stroke inches (mm) | L - extended inches (mm) |
|--------------|-----------------------|-----------------------------|
| GS-28-100-VA | 3.94 (100) | 10.31 (262) |
| GS-28-150-VA | 5.91 (150) | 14.25 (362) |
| GS-28-200-VA | 7.87 (200) | 18.19 (462) |
| GS-28-250-VA | 9.84 (250) | 22.13 (562) |
| GS-28-300-VA | 11.81 (300) | 26.06 (662) |
| GS-28-350-VA | 13.78 (350) | 30.00 (762) |
| GS-28-400-VA | 15.75 (400) | 33.94 (862) |
| GS-28-450-VA | 17.72 (450) | 37.87 (962) |
| GS-28-500-VA | 19.69 (500) | 41.81 (1,062) |
| GS-28-550-VA | 21.65 (550) | 45.75 (1,162) |
| GS-28-600-VA | 23.62 (600) | 49.69 (1,262) |
| GS-28-650-VA | 25.59 (650) | 53.62 (1,362) |

Ordering Example

GS-28-150-EE-1200-V4A

Type (Push Type) _____

Body Ø 1.1" (28 mm) _____

Stroke 5.91" (150 mm) _____

Piston Rod End Fitting E10-V4A _____

Body End Fitting E10-V4A _____

Nominal Force F₁ 270 lbs (1,200 N) _____

Indicated by K.-No. on delivery _____

The end fittings are interchangeable.
Strokes also available up to 29.53" (750 mm).

Stud Thread B10

Eye A10-VA
max. force 854 lbs (3,800 N)

Angle Ball Joint C10-VA
max. force 393 lbs (1,750 N)

Clevis Fork D10-VA
max. force 854 lbs (3,800 N)

Swivel Eye E10-VA
max. force 854 lbs (3,800 N)

Adjuster Knob U10-VA
See page 58.

Rod Shroud W10-28-VA

Ø 1.26 (32)

L = Stroke + 1.57 (40)

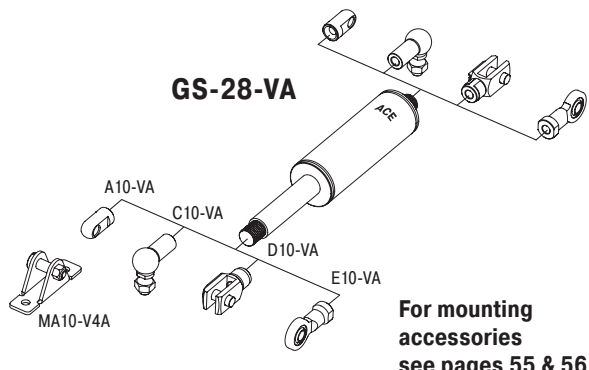

Technical Data

On request: Without damping, increased end position damping, special force curves, special lengths, alternative end fittings, wiper. Gas springs and accessories: Material 1.4404/1.4571, AISI 316L/316Ti (V4A).

Available force range F₁ at 68 °F (20 °C): 34 lbs to 562 lbs (150 N to 2,500 N)

Mounting: In any position

Advice: We recommend mounting with piston rod downwards to take advantage of the built-in end position damping.

End position damping length: Approx. 0.79" (20 mm) depending on the stroke

Material: Piston rod, body and end fittings: Material 1.4301/1.4305, AISI 304/303 (V2A).

Progression: Approx. 52%, F₂ max. 854 lbs (3,800 N)

End Fitting

Standard Dimensions – inches and (mm)

End Fitting

B14

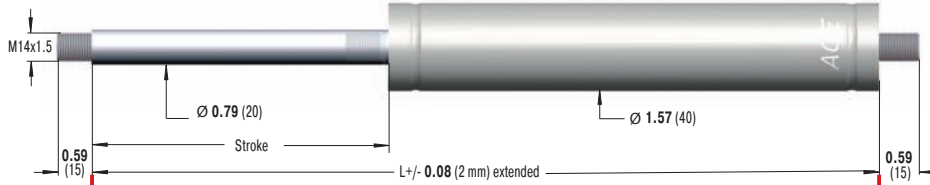

Stud Thread **B14**

A14-VA

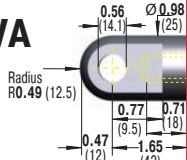

Dimensions

| Type | Stroke inches (mm) | L - extended inches (mm) |
|--------------|-----------------------|-----------------------------|
| GS-40-100-VA | 3.94 (100) | 12.48 (317) |
| GS-40-150-VA | 5.91 (150) | 16.42 (417) |
| GS-40-200-VA | 7.87 (200) | 20.35 (517) |
| GS-40-300-VA | 11.81 (300) | 28.23 (717) |
| GS-40-400-VA | 15.75 (400) | 36.10 (917) |
| GS-40-500-VA | 19.69 (500) | 43.98 (1,117) |
| GS-40-600-VA | 23.62 (600) | 51.85 (1,317) |

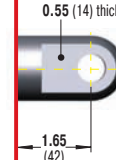

Eye A14-VA
max. force 1,574 lbs
(7,000 N)

C14-VA

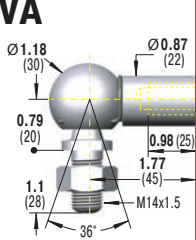

Angle Ball Joint C14-VA
max. force 719 lbs
(3,200 N)

D14-VA

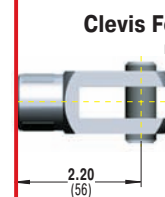
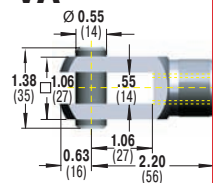

Clevis Fork D14-VA
max. force 1,574 lbs
(7,000 N)

E14-VA

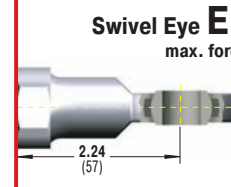
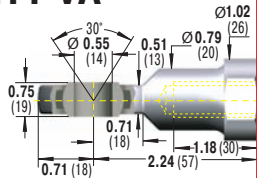

Swivel Eye E14-VA
max. force 1,574 lbs
(7,000 N)

Rod Shroud W14-40-VA

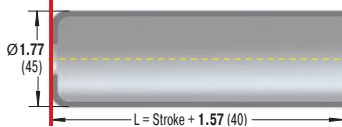

Ordering Example

GS-40-150-DD-3500-V4A

Type (Push Type) _____
 Body Ø 1.57" (40 mm) _____
 Stroke 5.91" (150 mm) _____
 Piston Rod End Fitting D14-V4A _____
 Body End Fitting D14-V4A _____
 Nominal Force F₁ 787 lbs (3,500 N) _____
 Indicated by K.-No. on delivery _____

The end fittings are interchangeable.
Strokes also available up to 39.37" (1,000 mm).

Adjuster Knob U14-VA
See page 58.

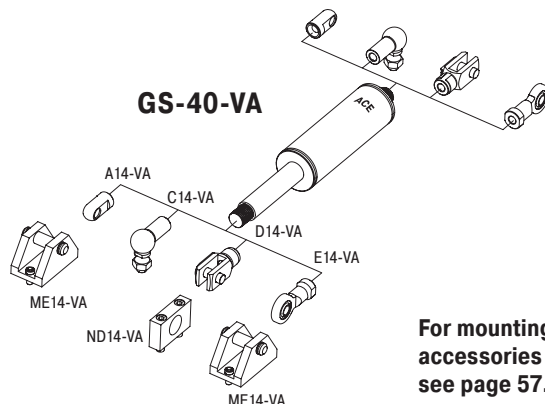
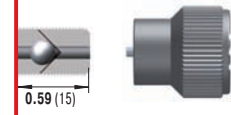

For mounting accessories see page 57.

Technical Data

On request: Without damping, increased end position damping, special force curves, special lengths, alternative end fittings, wiper. Gas springs and accessories: Material 1.4404/1.4571, AISI 316L/316Ti (V4A).

Available force range F₁ at 68 °F (20 °C): 112 lbs to 1,124 lbs (500 N to 5,000 N)

Mounting: In any position

Advice: We recommend mounting with piston rod downwards to take advantage of the built-in end position damping.

End position damping length: Approx. 2.24" (30 mm) depending on the stroke

Material: Piston rod, body and end fittings: Material 1.4301/1.4305, AISI 304/303 (V2A).

Progression: Approx. 40%, F₂ max. 1,574 lbs (7,000 N)

Industrial traction gas springs are maintenance-free and ready to install. They are available ex-stock with body diameters from 0.59" to 1.57" (15 mm to 40 mm) and forces from 7 lbs to 1,124 lbs (30 N to 5,000 N) with valve. **ACE traction gas springs offer a long service life due to the hard-chromed piston rod and integral sliding bearing.** They can be installed in any position. The traction force can be subsequently adjusted by means of the valve. The comprehensive range of fitting parts ensures easy installation and makes the traction gas springs universal in use. They supply the muscle force and enable the controlled raising and lowering of covers, hoods, flaps etc. With the free ACE calculation service, the traction gas springs are designed with mounting points to fit the individual application, and can be delivered ex-stock as express deliveries within 24 hours.

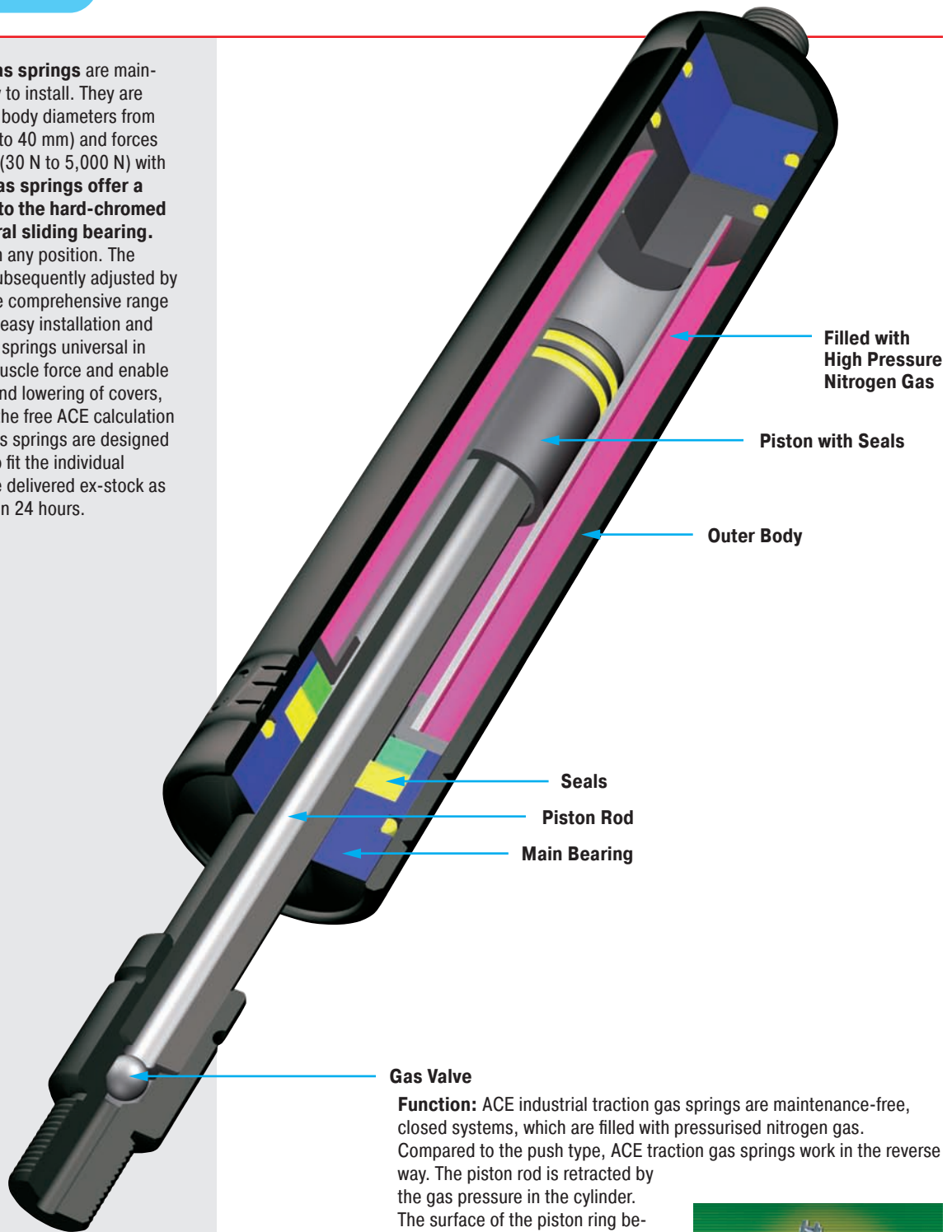

Gas Valve

Function: ACE industrial traction gas springs are maintenance-free, closed systems, which are filled with pressurised nitrogen gas. Compared to the push type, ACE traction gas springs work in the reverse way. The piston rod is retracted by the gas pressure in the cylinder. The surface of the piston ring between the piston rod and the inner tube determines the force of the gas spring. Traction gas springs are always mounted with the stroke fully compressed.

Operating fluid: Nitrogen gas

Mounting: In any position

Operating temperature range:

-4 °F to 176 °F (-20 °C to 80 °C)

On request: Special force curves, special lengths, alternative seals and end fittings.



Traction (Pull) Forces 7 lbs to 67 lbs (30 N to 300 N)
[when Piston Rod Extended up to 74 lbs (330 N)]

End Fitting

Standard Dimensions – inches and (mm)

End Fitting

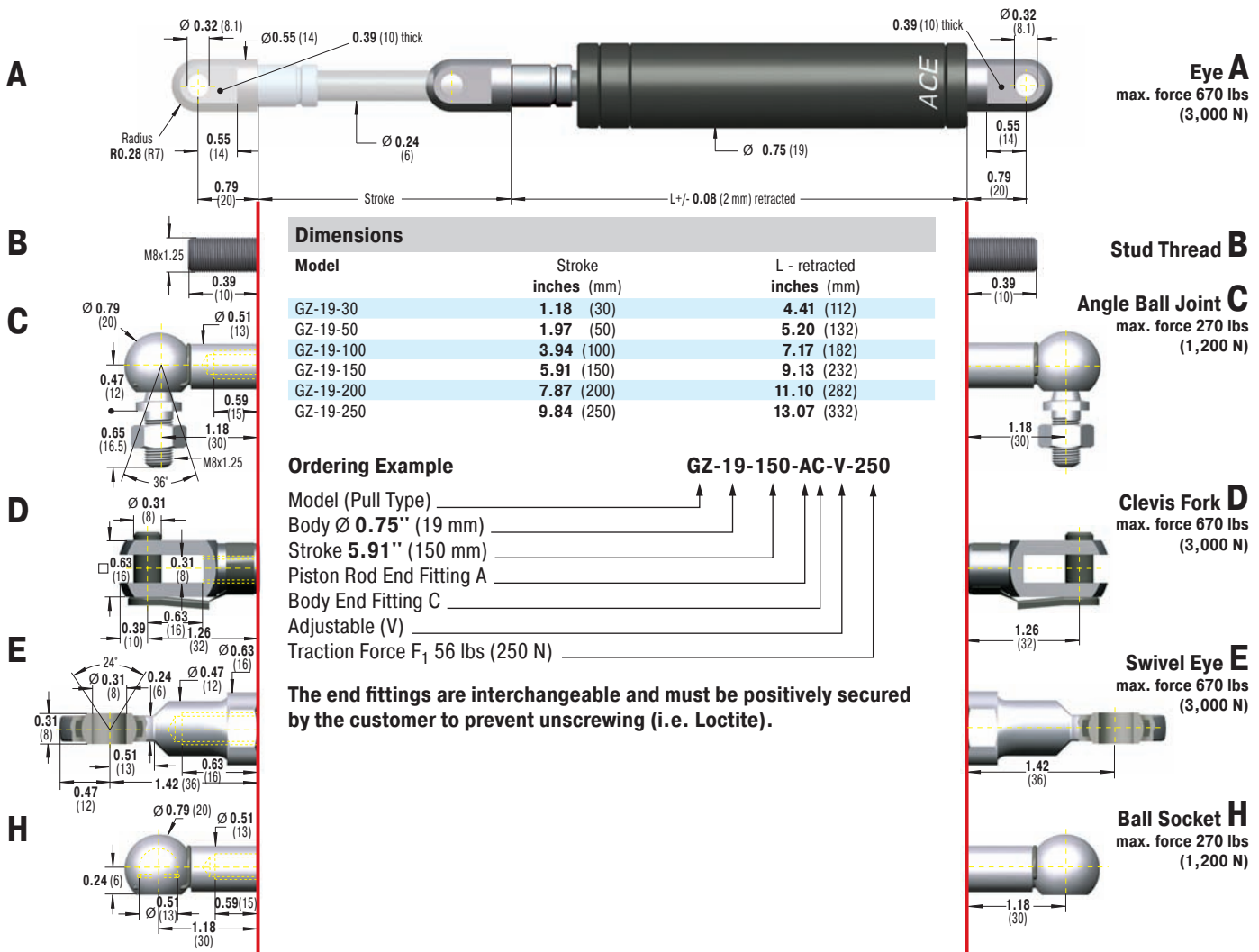

Rod Shroud W8-19

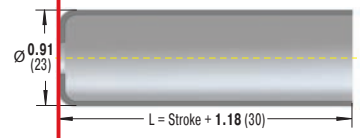

Adjuster Knob UZ8
See page 58.

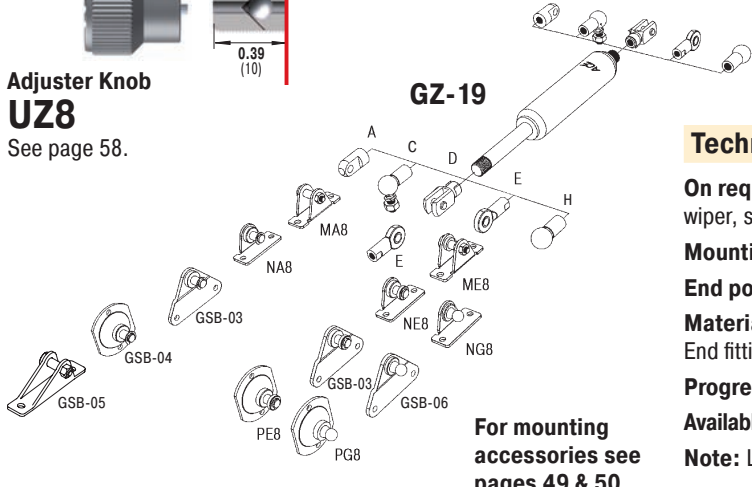

For mounting accessories see pages 49 & 50.

Technical Data

- On request:** Special force curves, special lengths, alternative end fittings, wiper, stainless steel.
- Mounting:** In any position. Install mechanical stop in extended position.
- End position damping length:** Without damping.
- Material:** Piston rod: Hard chrome plated. Body: black coated. End fittings: Zinc plated steel.
- Progression:** Approx. 10%, F₂ max. 74 lbs (330 N)
- Available traction force range F₁ at 68 °F (20 °C):** 7 lbs to 67 lbs (30 N to 300 N)
- Note:** Lifetime approx. 2,000 m



Industrial Traction Gas Springs GZ-28 (Pull Type)

Traction (Pull) Forces 34 lbs to 270 lbs (150 N to 1,200 N)
[when Piston Rod Extended up to 324 lbs (1,440 N)]

End Fitting

Standard Dimensions – inches and (mm)

End Fitting

A

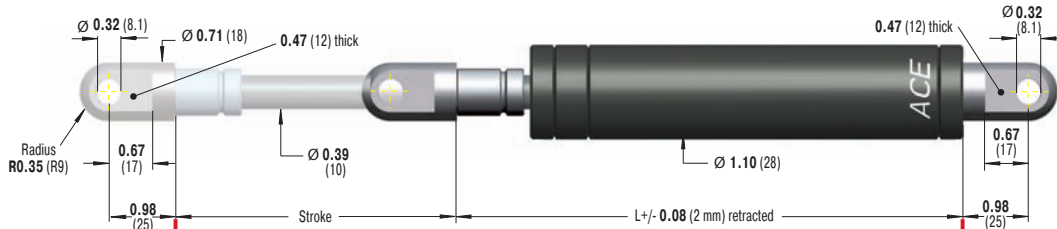

B

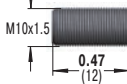

Stud Thread B

C

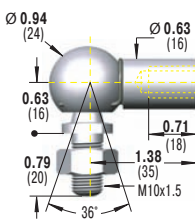

Angle Ball Joint C
max. force 405 lbs (1,800 N)

D

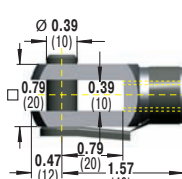

Clevis Fork D
max. force 2,248 lbs (10,000 N)

E

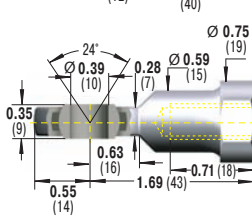

Swivel Eye E
max. force 2,248 lbs (10,000 N)

Dimensions

| Model | Stroke inches (mm) | L - retracted inches (mm) |
|-----------|-----------------------|------------------------------|
| GZ-28-30 | 1.18 (30) | 5.12 (130) |
| GZ-28-50 | 1.97 (50) | 5.91 (150) |
| GZ-28-100 | 3.94 (100) | 7.87 (200) |
| GZ-28-150 | 5.91 (150) | 9.84 (250) |
| GZ-28-200 | 7.87 (200) | 11.81 (300) |
| GZ-28-250 | 9.84 (250) | 13.78 (350) |
| GZ-28-300 | 11.81 (300) | 15.75 (400) |
| GZ-28-350 | 13.78 (350) | 17.72 (450) |
| GZ-28-400 | 15.75 (400) | 19.69 (500) |
| GZ-28-450 | 17.72 (450) | 21.65 (550) |
| GZ-28-500 | 19.69 (500) | 23.62 (600) |
| GZ-28-550 | 21.65 (550) | 25.59 (650) |
| GZ-28-600 | 23.62 (600) | 27.56 (700) |
| GZ-28-650 | 25.59 (650) | 29.53 (750) |

Ordering Example

GZ-28-150-EE-V-800

Type (Pull Type) _____
 Body Ø 1.10" (28 mm) _____
 Stroke 5.91" (150 mm) _____
 Piston Rod End Fitting E _____
 Body End Fitting E _____
 Adjustable (V) _____
 Traction Force F₁ 180 lbs (800 N) _____

The end fittings are interchangeable and must be positively secured by the customer to prevent unscrewing (i.e. Loctite).

Rod Shroud
W10-28

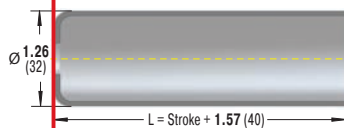

Adjuster Knob
UZ10

See page 58.

GZ-28

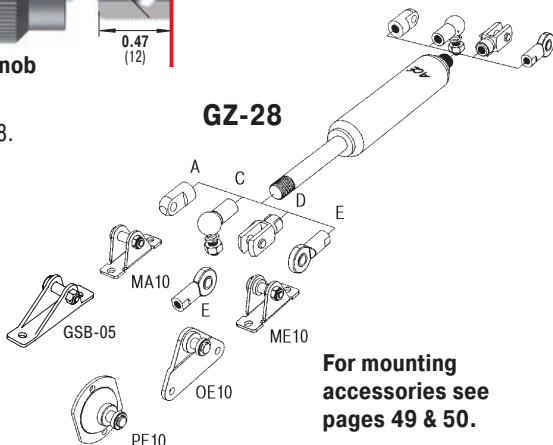

For mounting accessories see pages 49 & 50.

Technical Data

On request: Special force curves, special lengths, alternative end fittings, wiper, stainless steel.

Mounting: In any position. Install mechanical stop in extended position.

End position damping length: Without damping.

Material: Piston rod: Hard chrome plated. Body: black coated. End fittings: Zinc plated steel.

Progression: Approx. 20%, F₂ max. 324 lbs (1,440 N)

Available traction force range F₁ at 68 °F (20 °C): 34 lbs to 270 lbs (150 N to 1200 N)

Note: Lifetime approx. 2,000 m



Traction (Pull) Forces 90 lbs to 1,124 lbs (400 N to 5,000 N)
[when Piston Rod Extended up to 1,574 lbs (7,000 N)]

End Fitting

Standard Dimensions – inches and (mm)

End Fitting

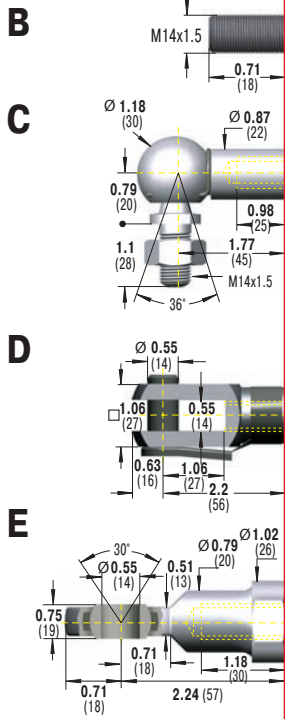
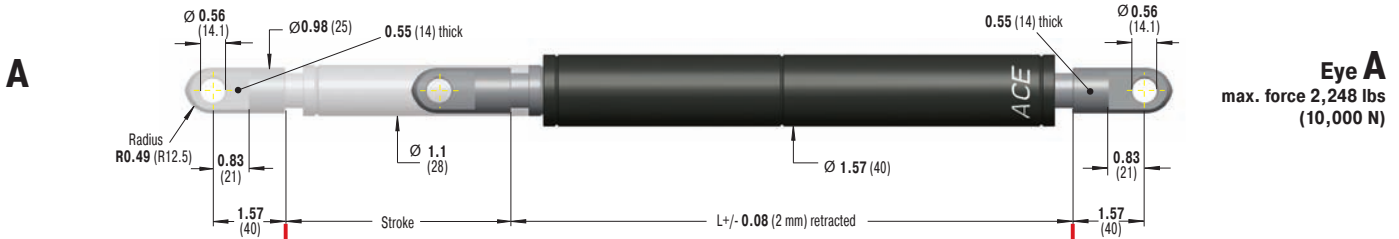

| Dimensions | | |
|------------|-----------------------|------------------------------|
| Model | Stroke inches (mm) | L - retracted inches (mm) |
| GZ-40-100 | 3.94 (100) | 9.84 (250) |
| GZ-40-150 | 5.91 (150) | 12.80 (325) |
| GZ-40-200 | 7.87 (200) | 15.75 (400) |
| GZ-40-250 | 9.84 (250) | 18.70 (475) |
| GZ-40-300 | 11.81 (300) | 21.65 (550) |
| GZ-40-400 | 15.75 (400) | 27.56 (700) |
| GZ-40-500 | 19.69 (500) | 33.46 (850) |
| GZ-40-600 | 23.62 (600) | 39.37 (1,000) |

Ordering Example
GZ-40-150-EE-V-800
 Model (Pull Type) _____
 Body Ø 1.57" (40 mm) _____
 Stroke 5.91" (150 mm) _____
 Piston Rod End Fitting E _____
 Body End Fitting E _____
 Adjustable (V) _____
 Traction Force F₁ 180 lbs (800 N) _____

The end fittings are interchangeable and must be positively secured by the customer to prevent unscrewing (i.e. Loctite).

Rod Shroud W14-40

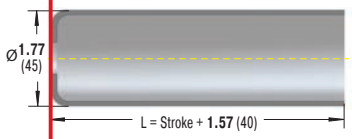

Adjuster Knob UZ14

See page 58.

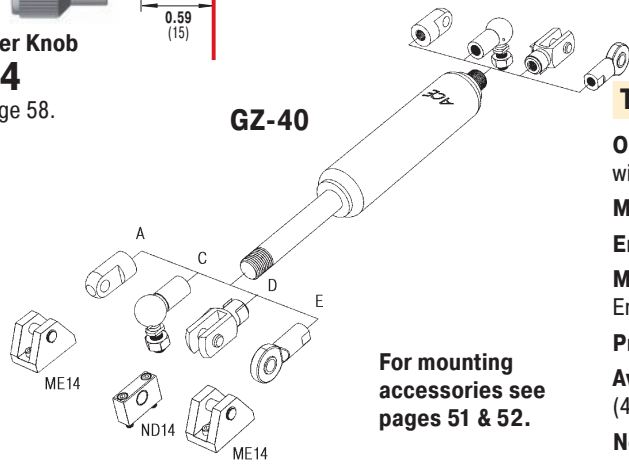
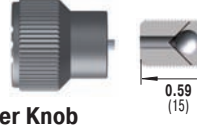

For mounting accessories see pages 51 & 52.

Technical Data

- On request:** Special force curves, special lengths, alternative end fittings, wiper, stainless steel.
- Mounting:** In any position. Install mechanical stop in extended position.
- End position damping length:** Without damping
- Material:** Piston rod: Hard chrome plated. Body: black coated. End fittings: Zinc plated steel.
- Progression:** approx. 40%, F₂ max. 1,574 (7,000 N)
- Available traction force range F₁ at 68 °F (20 °C):** 90 lbs to 1,124 lbs (400 N to 5,000 N)
- Note:** Lifetime approx. 2,000 m

Stainless steel industrial traction gas springs

Material 1.4301/1.4305, AISI 304/303 (V2A)
 Material 1.4404/1.4571, AISI 316L/316Ti (V4A)

In addition to the comprehensive range of industrial gas springs with valve, ACE also offers a wide range of industrial traction gas springs made of stainless steel with body diameters from 0.59" to 1.57" (15 mm to 40 mm). This high-quality version is also available on request in all stroke lengths and possible extension forces. The comprehensive range of fitting parts ensures easy installation and makes the gas traction springs universal in use. Stainless steel traction gas springs are used everywhere that raising and lowering is required. Due to their special properties, **non-rusting and low magnetism**, they are the preferred equipment for medical and clean-room technology, the foodstuffs industry, electronics and shipbuilding sector.

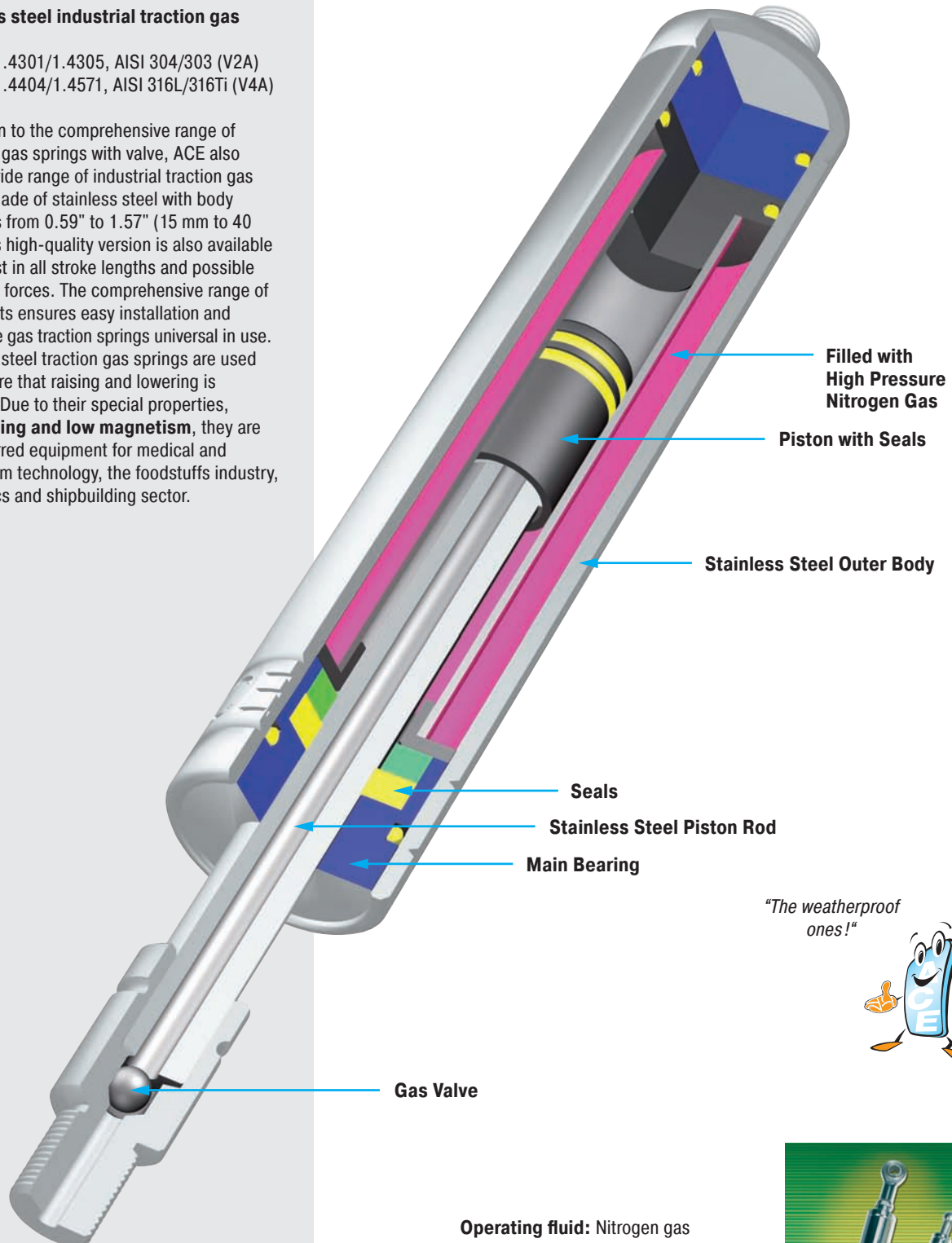

"The weatherproof ones!"



Operating fluid: Nitrogen gas

Material: Piston rod, body and end fittings: Material 1.4301/1.4305, AISI 304/303 (V2A) and material 1.4404/1.4571, AISI 316L/316Ti (V4A).

Mounting: In any position

Operating temperature range: -4 °F to 176 °F (-20 °C to 80 °C)

On request: Special force curves, special lengths, alternative seals, wiper.



Traction (Pull) Forces 11 lbs to 67 lbs (50 N to 300 N)
[when Piston Rod Extended up to 83 lbs (370 N)]

End Fitting

Standard Dimensions – inches and (mm)

End Fitting

B3,5

Stud Thread B3,5

A3,5-V4A

Eye
A3,5-V4A
max. force 83 lbs
(370 N)

C3,5-V4A

Angle Ball Joint
C3,5-V4A
max. force 83 lbs
(370 N)

D3,5-V4A

Clevis Fork
D3,5-V4A
max. force 83 lbs
(370 N)

G3,5-V4A

Ball Socket
G3,5-V4A
max. force 83 lbs
(370 N)

Adjuster Knob U3,5
See page 58.

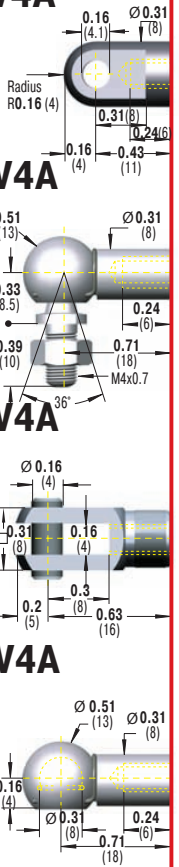
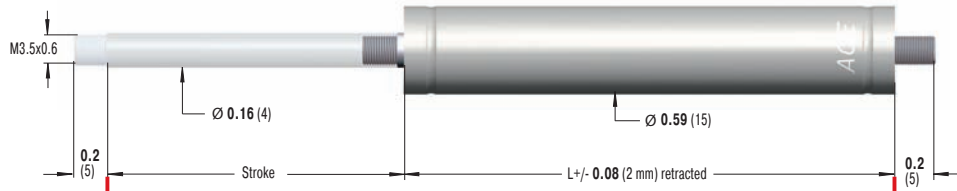

| Dimensions | | |
|---------------|-----------------------|------------------------------|
| Model | Stroke inches (mm) | L - retracted inches (mm) |
| GZ-15-20-V4A | 0.79 (20) | 3.43 (87) |
| GZ-15-40-V4A | 1.57 (40) | 4.21 (107) |
| GZ-15-50-V4A | 1.97 (50) | 4.61 (117) |
| GZ-15-60-V4A | 2.36 (60) | 5.00 (127) |
| GZ-15-80-V4A | 3.15 (80) | 5.79 (147) |
| GZ-15-100-V4A | 3.94 (100) | 6.57 (167) |
| GZ-15-120-V4A | 4.72 (120) | 7.36 (187) |
| GZ-15-150-V4A | 5.91 (150) | 8.54 (217) |

Ordering Example GZ-15-150-AC-150-V4A

Model (Pull Type) _____

Body Ø 0.59" (15 mm) _____

Stroke 5.91" (150 mm) _____

Piston Rod End Fitting A3,5-V4A _____

Body End Fitting C3,5-V4A _____

Traction Force F₁ 34 lbs (150 N) _____

Indicated by K.-No. on delivery _____

The end fittings are interchangeable.

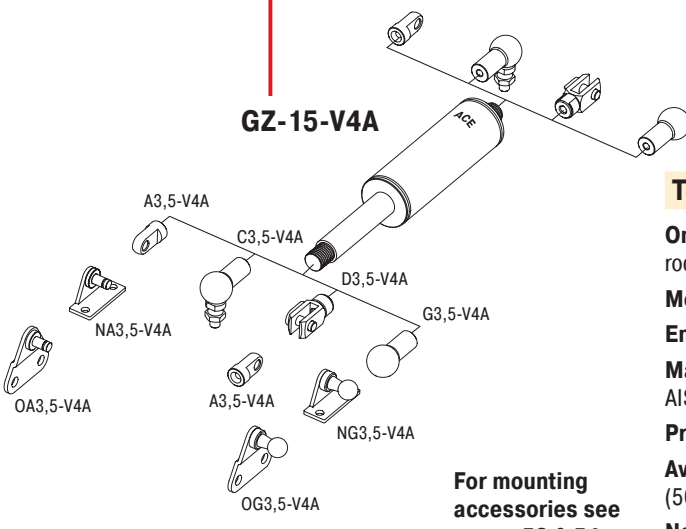

For mounting accessories see pages 53 & 54.

Technical Data

- On request:** Special force curves, special lengths, alternative end fittings, rod shroud.
- Mounting:** In any position. Install mechanical stop in extended position.
- End position damping length:** Without damping
- Material:** Piston rod, body and end fittings: Material 1.4571/1.4404, AISI 316L/316Ti (V4A).
- Progression:** approx. 23%, F₂ max. 83 lbs (370 N)
- Available traction force F₁ at 68 °F (20 °C):** 11 lbs to 67 lbs (50 N to 300 N)
- Note:** Lifetime approx. 2,000 m

Traction (Pull) Forces 7 lbs to 67 lbs (30 N to 300 N)
[when Piston Rod Extended up to 75 lbs (333 N)]

End Fitting

Standard Dimensions – inches and (mm)

End Fitting

B8

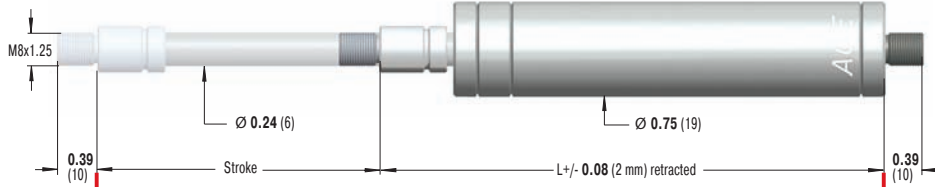

Stud Thread **B8**

A8-V4A

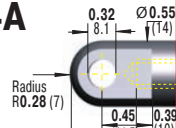

Dimensions

| Model | Stroke inches (mm) | L - retracted inches (mm) |
|---------------|-----------------------|------------------------------|
| GZ-19-30-V4A | 1.18 (30) | 5.12 (130) |
| GZ-19-50-V4A | 1.97 (50) | 5.91 (150) |
| GZ-19-100-V4A | 3.94 (100) | 7.87 (200) |
| GZ-19-150-V4A | 5.91 (150) | 9.84 (250) |
| GZ-19-200-V4A | 7.87 (200) | 11.81 (300) |
| GZ-19-250-V4A | 9.84 (250) | 13.78 (350) |

Eye
A8-V4A
max. force 351 lbs
(1,560 N)

C8-V4A

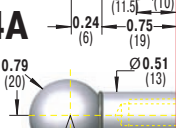

Angle Ball Joint
C8-V4A
max. force 256 lbs
(1,140 N)

D8-V4A

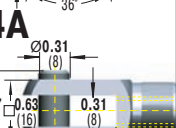

Clevis Fork
D8-V4A
max. force 351 lbs
(1,560 N)

E8-V4A

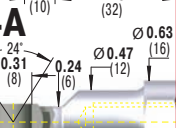

Swivel Eye
E8-V4A
max. force 351 lbs
(1,560 N)

G8-V4A

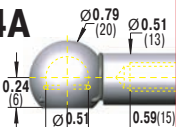

Ball Socket
G8-V4A
max. force 256 lbs
(1,140 N)

Rod Shroud
W8-19-V4A

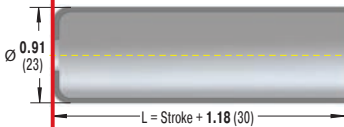

Ordering Example **GZ-19-150-AC-150-V4A**

Model (Pull Type) _____
 Body Ø **0.75"** (19 mm) _____
 Stroke **5.91"** (150 mm) _____
 Piston Rod End Fitting **A8-V4A** _____
 Body End Fitting **C8-V4A** _____
 Traction Force **F₁ 34 lbs** (150 N) _____
 Indicated by K.-No. on delivery _____

The end fittings are interchangeable.

Adjuster Knob
UZ8

See page 58.

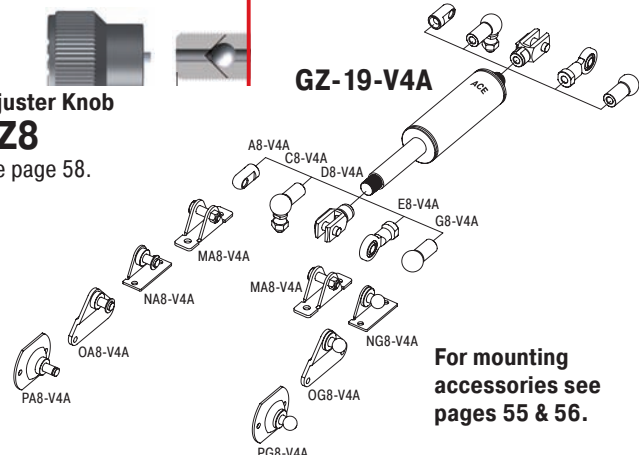

For mounting accessories see pages 55 & 56.

Technical Data

- On request:** Special force curves, special lengths, alternative end fittings and wiper.
- Mounting:** In any position. Install mechanical stop in extended position.
- End position damping length:** Without damping
- Material:** Piston rod, body and end fittings: AISI 316L/316Ti (V4A).
- Progression:** Approx. 11 %, F₂ max. 75 lbs (333 N)
- Available traction force range F₁ at 68 °F (20 °C):** 7 lbs to 67 lbs (30 N to 300 N)
- Note:** Lifetime approx. 2,000 m

Traction (Pull) Forces 34 lbs to 270 lbs (150 N to 1,200 N)
[when Piston Rod Extended up to 328 lbs (1,460 N)]

End Fitting

Standard Dimensions – inches and (mm)

End Fitting

B10

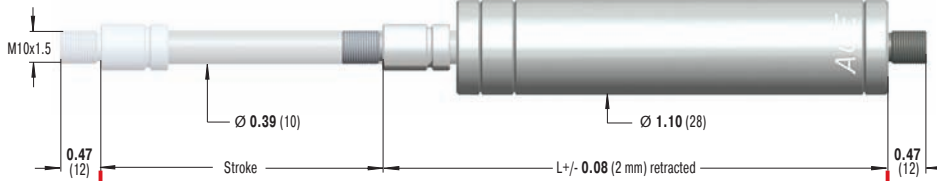

Stud Thread **B10**

A10-V4A

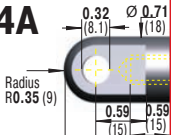

Dimensions

| Model | Stroke inches (mm) | L - retracted inches (mm) |
|---------------|-----------------------|------------------------------|
| GZ-28-50-V4A | 1.97 (50) | 6.50 (165) |
| GZ-28-100-V4A | 3.94 (100) | 8.46 (215) |
| GZ-28-150-V4A | 5.91 (150) | 10.43 (265) |
| GZ-28-200-V4A | 7.87 (200) | 12.40 (315) |
| GZ-28-250-V4A | 9.84 (250) | 14.37 (365) |
| GZ-28-300-V4A | 11.81 (300) | 16.34 (415) |
| GZ-28-350-V4A | 13.78 (350) | 18.31 (465) |
| GZ-28-400-V4A | 15.75 (400) | 20.28 (515) |
| GZ-28-450-V4A | 17.72 (450) | 22.24 (565) |
| GZ-28-500-V4A | 19.69 (500) | 24.21 (615) |
| GZ-28-550-V4A | 21.65 (550) | 26.18 (665) |
| GZ-28-600-V4A | 23.62 (600) | 28.15 (715) |

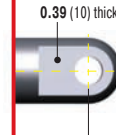

**Eye
A10-V4A**
max. force 854 lbs
(3,800 N)

C10-V4A

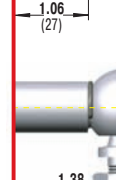
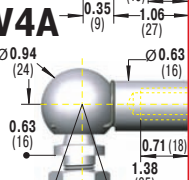

**Angle Ball Joint
C10-V4A**
max. force 393 lbs
(1,750 N)

D10-V4A

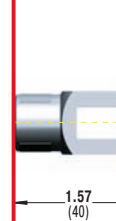
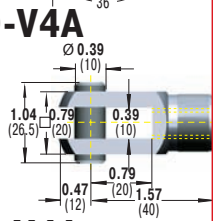

**Clevis Fork
D10-V4A**
max. force 854 lbs
(3,800 N)

E10-V4A

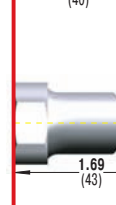
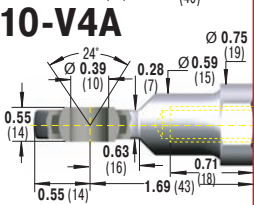

**Swivel Eye
E10-V4A**
max. force 854 lbs
(3,800 N)

Ordering Example

Model (Pull Type) **GZ-28-150-EE-800-VA**
 Body \varnothing 1.10" (28 mm)
 Stroke 5.91" (150 mm)
 Piston Rod End Fitting E10-VA
 Body End Fitting E10-VA
 Traction Force F_1 180 lbs (800 N)
 Indicated by K.-No. on delivery

The end fittings are interchangeable.

**Rod Shroud
W10-28-V4A**

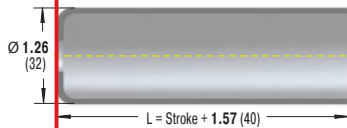

**Adjuster Knob
UZ10**

See page 58.

GZ-28-V4A

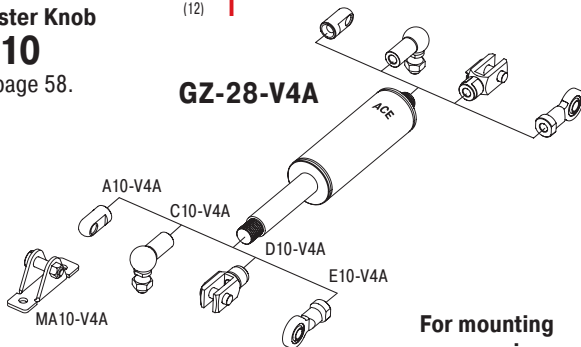

For mounting accessories see pages 55 & 56.

Technical Data

On request: Special force curves, special lengths, alternative end fittings and wiper.

Mounting: In any position. Install mechanical stop in extended position.

End position damping length: Without damping

Material: Piston rod, body and end fittings: AISI 316L/316Ti (V4A).

Progression: Approx. 22%, F_2 max. 328 lbs (1,460 N)

Available traction force range F_1 at 68 °F (20 °C): 34 lbs to 270 lbs (150 N to 1200 N)

Note: Lifetime approx. 2,000 m

Traction (Pull) Forces 90 lbs to 1,124 lbs (400 N to 5,000 N)
[when Piston Rod Extended up to 1,574 lbs (7,000 N)]

End Fitting

Standard Dimensions – inches and (mm)

End Fitting

B14

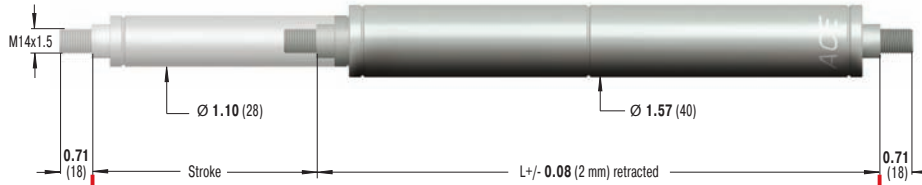

Stud Thread **B14**

A14-V4A

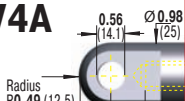

Dimensions

| Model | Stroke inches (mm) | L - retracted inches (mm) |
|---------------|-----------------------|------------------------------|
| GZ-40-100-V4A | 3.94 (100) | 9.84 (250) |
| GZ-40-150-V4A | 5.91 (150) | 12.80 (325) |
| GZ-40-200-V4A | 7.87 (200) | 15.75 (400) |
| GZ-40-250-V4A | 9.84 (250) | 18.70 (475) |
| GZ-40-300-V4A | 11.81 (300) | 21.65 (550) |
| GZ-40-400-V4A | 15.75 (400) | 27.56 (700) |
| GZ-40-500-V4A | 19.69 (500) | 33.46 (850) |
| GZ-40-600-V4A | 23.62 (600) | 39.37 (1,000) |



**Eye
A14-V4A**
max. force 1,574 lbs
(7,000 N)

C14-V4A

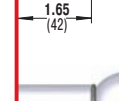
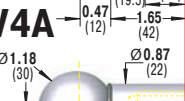

**Angle Ball Joint
C14-V4A**
max. force 719 lbs
(3,200 N)

D14-V4A

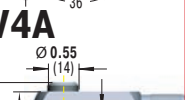

**Clevis Fork
D14-V4A**
max. force 1,574 lbs
(7,000 N)

E14-V4A

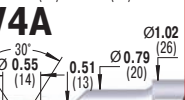

**Swivel Eye
E14-V4A**
max. force 1,574 lbs
(7,000 N)

Ordering Example

GZ-40-150-EE-800-V4A

Model (Pull Type) _____
 Body Ø 1.57" (40 mm) _____
 Stroke 5.91" (150 mm) _____
 Piston Rod End Fitting E14-V4A _____
 Body End Fitting E14-V4A _____
 Traction Force F₁ 180 lbs (800 N) _____
 Indicated by K.-No. on delivery _____

The end fittings are interchangeable.

**Rod Shroud
W14-40-V4A**

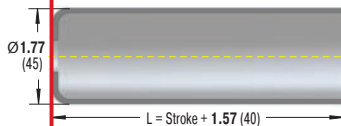

**Adjuster Knob
UZ14**

See page 58.

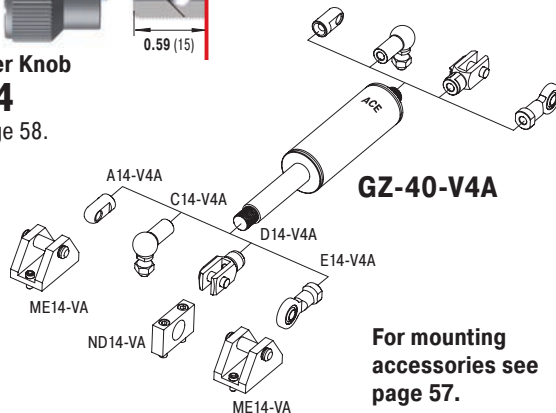

GZ-40-V4A

For mounting accessories see page 57.

Technical Data

On request: Special force curves, special lengths, alternative end fittings and wiper.

Mounting: In any position. Install mechanical stop in extended position.

End position damping length: Without damping

Material: Piston rod, body and end fittings: AISI 316L/316Ti (V4A).

Progression: Approx. 40%, F₂ max. 1,574 lbs (7,000 N)

Available traction force range F₁ at 68 °F (20 °C): 90 lbs to 1,124 lbs (400 N to 5,000 N)

Note: Lifetime approx. 2,000 m

Traction (Pull) Forces 7 lbs to 67 lbs (30 N to 300 N)
[when Piston Rod Extended up to 75 lbs (333 N)]

End Fitting

Standard Dimensions – inches and (mm)

End Fitting

B8

Stud Thread B8

A8-VA

Eye
A8-VA

max. force 351 lbs
(1,560 N)

C8-VA

Angle Ball Joint
C8-VA

max. force 256 lbs
(1,140 N)

D8-VA

Clevis Fork
D8-VA

max. force 351 lbs
(1,560 N)

E8-VA

Swivel Eye
E8-VA

max. force 351 lbs
(1,560 N)

G8-VA

Ball Socket
G8-VA

max. force 256 lbs
(1,140 N)

Rod Shroud
W8-19-VA

Dimensions

| Model | Stroke inches (mm) | L - retracted inches (mm) |
|--------------|-----------------------|------------------------------|
| GZ-19-30-VA | 1.18 (30) | 5.12 (130) |
| GZ-19-50-VA | 1.97 (50) | 5.91 (150) |
| GZ-19-100-VA | 3.94 (100) | 7.87 (200) |
| GZ-19-150-VA | 5.91 (150) | 9.84 (250) |
| GZ-19-200-VA | 7.87 (200) | 11.81 (300) |
| GZ-19-250-VA | 9.84 (250) | 13.78 (350) |

Ordering Example

Model (Pull Type) **GZ-19-150-AC-150-VA**
 Body Ø 0.75 (19 mm)
 Stroke 5.91 (150 mm)
 Piston Rod End Fitting A8-VA
 Body End Fitting C8-VA
 Traction Force F₁ 34 lbs (150 N)
 Indicated by K.-No. on delivery

The end fittings are interchangeable.

Technical Data

On request: Special force curves, special lengths, alternative end fittings, wiper. Gas springs and accessories with material 1.4404/1.4571 (V4A).

Mounting: In any position. Install mechanical stop in extended position.

End position damping length: Without damping

Material: Piston rod: Material 1.4401, AISI 316L (V4A). Body and end fittings: Material 1.4301, AISI 304 (V2A).

Progression: Approx. 11%, F₂ max. 75 lbs (333 N)

Available traction force range F₁ at 68 °F (20 °C): 7 lbs to 67 lbs (30 N to 300 N)

Note: Lifetime approx. 2,000 m

Adjuster Knob

UZ8

See pag 58.

GZ-19-VA

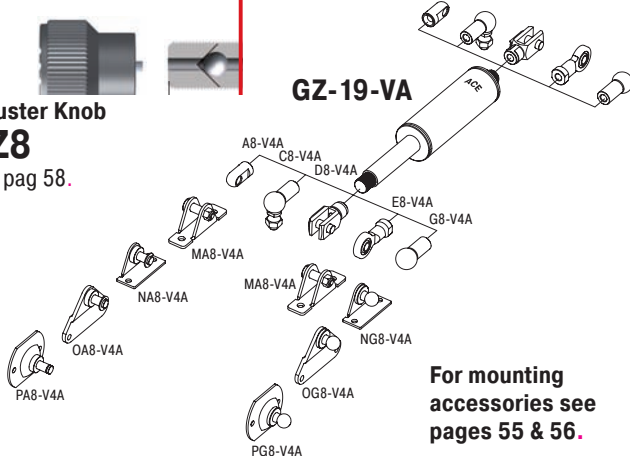

For mounting accessories see pages 55 & 56.



Stainless Steel Traction Gas Springs GZ-28-VA (Pull Type)

Traction (Pull) Forces 34 lbs to 270 lbs (150 N to 1,200 N)
[when Piston Rod Extended up to 328 lbs (1,460 N)]

End Fitting

Standard Dimensions – inches and (mm)

End Fitting

B10

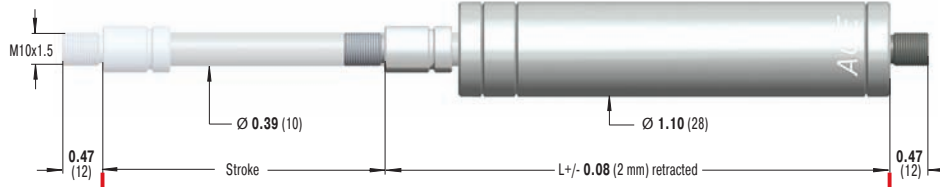

Stud Thread **B10**

A10-VA

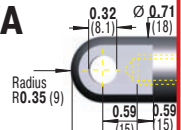

Dimensions

| Model | Stroke inches (mm) | L - retracted inches (mm) |
|--------------|-----------------------|------------------------------|
| GZ-28-50-VA | 1.97 (50) | 6.50 (165) |
| GZ-28-100-VA | 3.94 (100) | 8.46 (215) |
| GZ-28-150-VA | 5.91 (150) | 10.43 (265) |
| GZ-28-200-VA | 7.87 (200) | 12.40 (315) |
| GZ-28-250-VA | 9.84 (250) | 14.37 (365) |
| GZ-28-300-VA | 11.81 (300) | 16.34 (415) |
| GZ-28-350-VA | 13.78 (350) | 18.31 (465) |
| GZ-28-400-VA | 15.75 (400) | 20.28 (515) |
| GZ-28-450-VA | 17.72 (450) | 22.24 (565) |
| GZ-28-500-VA | 19.69 (500) | 24.21 (615) |
| GZ-28-550-VA | 21.65 (550) | 26.18 (665) |
| GZ-28-600-VA | 23.62 (600) | 28.15 (715) |

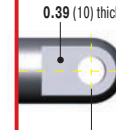

Eye A10-VA
max. force 854 lbs (3,800 N)

C10-VA

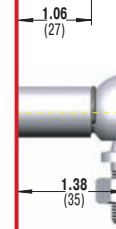
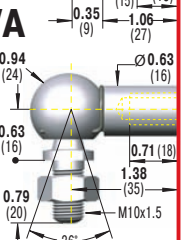

Angle Ball Joint C10-VA
max. force 393 lbs (1,750 N)

D10-VA

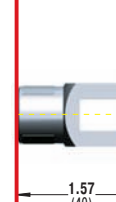
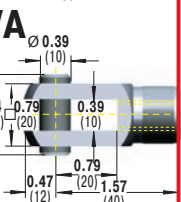

Clevis Fork D10-VA
max. force 854 lbs (3,800 N)

E10-VA

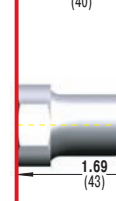
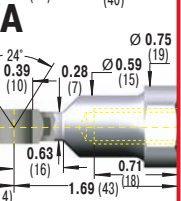

Swivel Eye E10-VA
max. force 854 lbs (3,800 N)

Ordering Example

GZ-28-150-EE-800-VA

- Model (Pull Type) _____
- Body Ø **1.10"** (28 mm) _____
- Stroke **5.91"** (150 mm) _____
- Piston Rod End Fitting E10-VA _____
- Body End Fitting E10-VA _____
- Traction Force F₁ **180 lbs** (800 N) _____
- Indicated by K.-No. on delivery _____

The end fittings are interchangeable.

Rod Shroud **W10-28-VA**

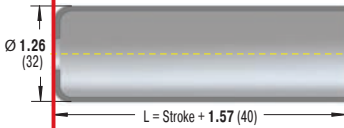

Adjuster Knob **UZ10**
See page 58.

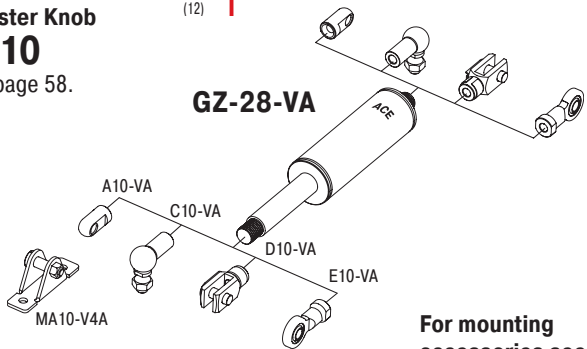

For mounting accessories see pages 55 & 56.

Technical Data

- On request:** Special force curves, special lengths, alternative end fittings, wiper. Gas springs and accessories with material 1.4404/1.4571 (VA).
- Mounting:** In any position. Install mechanical stop in extended position.
- End position damping length:** Without damping
- Material:** Piston rod, body and end fittings: Material 1.4301/1.4305, AISI 304/303 (V2A).
- Progression:** Approx. 22%, F₂ max. 328 lbs (1,460 N)
- Available traction force range F₁ at 68 °F (20 °C):** 34 lbs to 270 lbs (150 N to 1200 N)
- Note:** Lifetime approx. 2,000 m

Traction (Pull) Forces 90 lbs to 1,124 lbs (400 N to 5,000 N)
[when Piston Rod Extended up to 1,574 lbs (7,000 N)]

End Fitting

Standard Dimensions – inches and (mm)

End Fitting

B14

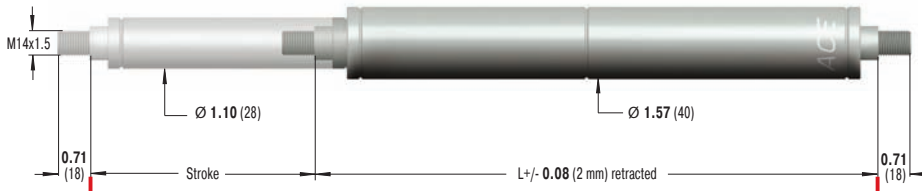

Stud Thread **B14**

A14-VA

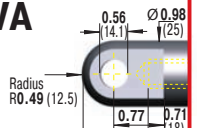

| Model | Stroke | | L - retracted | |
|--------------|--------|-------|---------------|---------|
| | inches | (mm) | inches | (mm) |
| GZ-40-100-VA | 3.94 | (100) | 9.84 | (250) |
| GZ-40-150-VA | 5.91 | (150) | 12.80 | (325) |
| GZ-40-200-VA | 7.87 | (200) | 15.75 | (400) |
| GZ-40-250-VA | 9.84 | (250) | 18.70 | (475) |
| GZ-40-300-VA | 11.81 | (300) | 21.65 | (550) |
| GZ-40-400-VA | 15.75 | (400) | 27.56 | (700) |
| GZ-40-500-VA | 19.69 | (500) | 33.46 | (850) |
| GZ-40-600-VA | 23.62 | (600) | 39.37 | (1,000) |

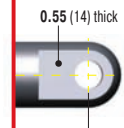

Eye A14-VA
max. force 1,574 lbs (7,000 N)

C14-VA

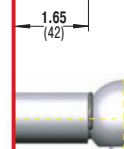
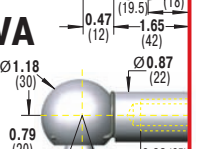

Angle Ball Joint C14-VA
max. force 719 lbs (3,200 N)

D14-VA

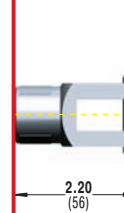
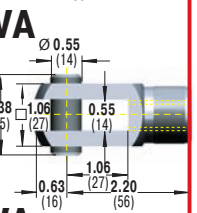

Clevis Fork D14-VA
max. force 1,574 lbs (7,000 N)

E14-VA

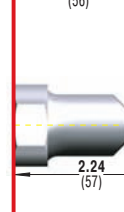
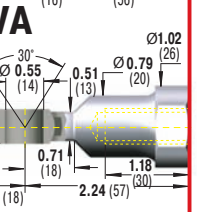

Swivel Eye E14-VA
max. force 1,574 lbs (7,000 N)

Ordering Example

GZ-40-150-EE-800-VA

Model (Pull Type) _____
 Body Ø 1.57" (40 mm) _____
 Stroke 5.91" (150 mm) _____
 Piston Rod End Fitting E14-VA _____
 Body End Fitting E14-VA _____
 Traction Force F₁ 180 lbs (800 N) _____
 Indicated by K.-No. on delivery _____

The end fittings are interchangeable.

Rod Shroud W14-40-VA

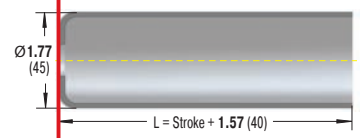

Adjuster Knob UZ14

See page 58.

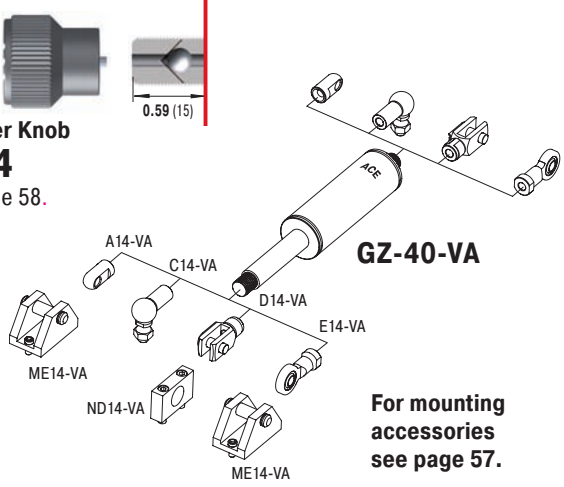

GZ-40-VA
For mounting accessories see page 57.

Technical Data

On request: Special force curves, special lengths, alternative end fittings, wiper. Gas springs and accessories with material 1.4404/1.4571 (V4A).
Mounting: In any position. Install mechanical stop in extended position.
End position damping length: Without damping
Material: Piston rod, body and end fittings: Material 1.4301/1.4305, AISI 304/303 (V2A).
Progression: Approx. 40 %, F₂ max. 1,574 lbs (7,000 N)
Available traction force range F₁ at 68 °F (20 °C): 90 lbs to 1,124 lbs (400 N to 5,000 N)
Note: Lifetime approx. 2,000 m

By taking advantage of the very extensive range of **ACE end fittings and mounting brackets** you can easily and simply install our gas springs. You profit from the variety of **DIN Standard** end fittings such as swivel eyes, clevis forks, angle ball joints, inline ball joints, and complementary ball sockets. ACE also offers eye fittings made of wear-resistant steel to meet the higher specification requirements found in industrial applications. With over 30 different types available these mounting accessories provide an extensive range of combinations for optimum installations.

The complete range of accessories are also available as individual components.

"Just drill 4 holes – ACE does all the rest!"



**Interchangeable
Combinable**

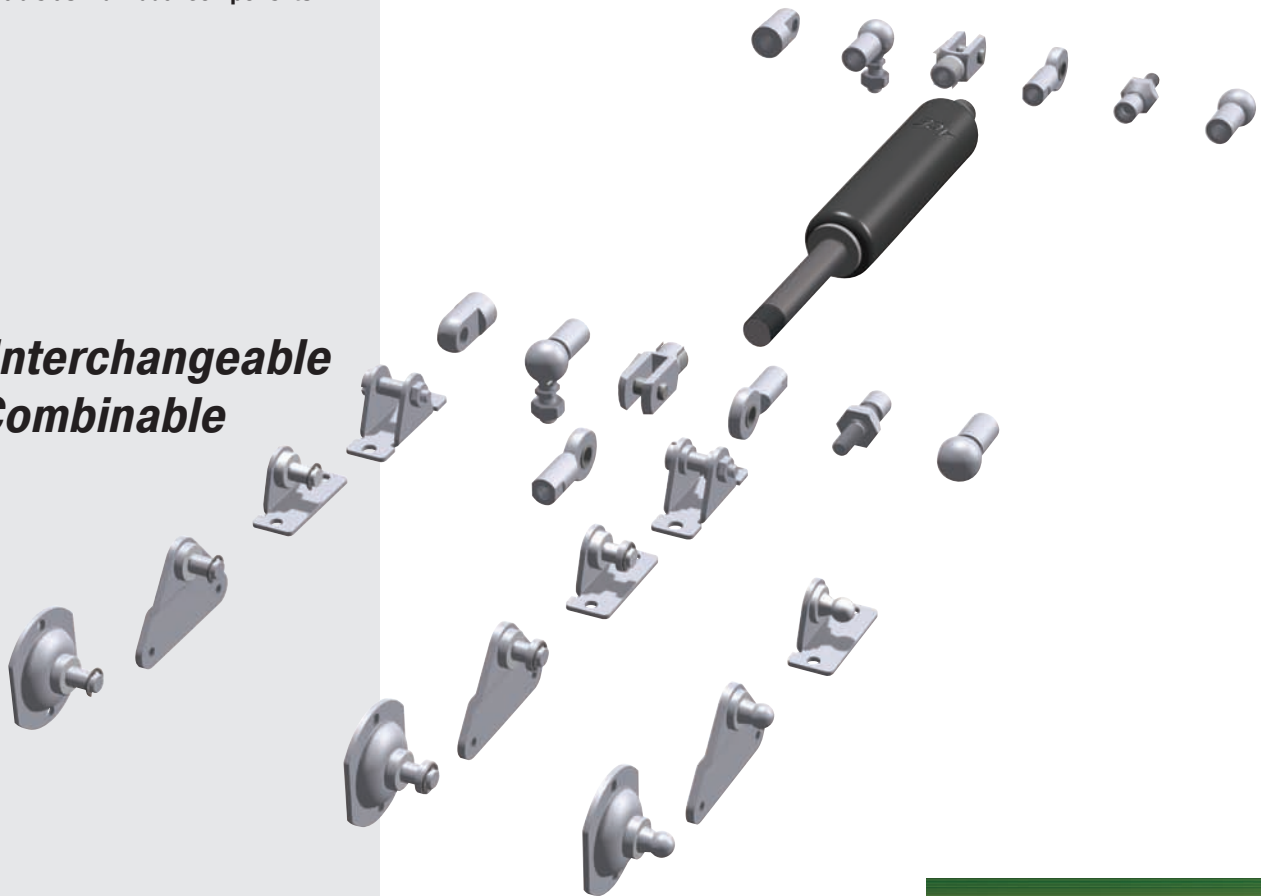

The wide range of mounting brackets available

Accessories M3.5x0.6

GS-8, GS-10, GS-12, GZ-15

Imperial

| | | | | |
|---|--|---|--|---|
| <p>A3,5 Eye</p> <p>1 max. force 83 lbs</p> | <p>C3,5 Angle Ball Joint DIN 71802</p> <p>1 max. force 83 lbs</p> | <p>D3,5 Clevis Fork DIN 71752</p> <p>1 max. force 83 lbs</p> | <p>E3,5 Swivel Eye DIN 648</p> <p>1 max. force 83 lbs</p> | <p>G3,5 Ball Socket DIN 71805</p> <p>1 max. force 83 lbs</p> |
| <p>1 max. force 40 lbs</p> | <p>NA3,5</p> | <p>NG3,5</p> | <p>1 max. force 40 lbs</p> | <p>OA3,5</p> <p>OG3,5</p> |

Accessories M5x0.8

AGS-15

Imperial

| | | | | |
|---|--|---|--|---|
| <p>A Eye</p> <p>1 max. force 90 lbs</p> | <p>C Angle Ball Joint DIN 71802</p> <p>1 max. force 112 lbs</p> | <p>D Clevis Fork DIN 71752</p> <p>1 max. force 180 lbs</p> | <p>E Swivel Eye DIN 648</p> <p>1 max. force 180 lbs</p> | <p>F Inline Ball Joint</p> <p>Attention! Must only be used with compression loads.</p> <p>1 max. force 112 lbs</p> |
| <p>H Ball Socket DIN 71805</p> <p>1 max. force 112 lbs</p> | <p>1 max. force 112 lbs</p> | <p>MA5</p> | <p>1 max. force 90 lbs</p> | <p>NA5</p> <p>NG5</p> |
| <p>1 max. force 112 lbs</p> | <p>GSB-01</p> | <p>*GSB-02</p> <p>Ball</p> | <p>1 max. force 112 lbs</p> | <p>PA5</p> <p>PG5</p> |

1 Attention! Max. static load in pounds (lbs). Beware force increase during compression (progression) and observe max. force limit.

*C end fitting, minus threaded stud, adapts to GSB-02.

Accessories M3.5x0.6

GS-8, GS-10, GS-12, GZ-15

Metric

| | | | | |
|--|---|--|---|--|
| <p>A3,5 Eye</p> <p>1 max. force 370 N</p> | <p>C3,5 Angle Ball Joint DIN 71802</p> <p>1 max. force 370 N</p> | <p>D3,5 Clevis Fork DIN 71752</p> <p>1 max. force 370 N</p> | <p>E3,5 Swivel Eye DIN 648</p> <p>1 max. force 370 N</p> | <p>G3,5 Ball Socket DIN 71805</p> <p>1 max. force 370 N</p> |
| <p>1 max. force 180 N</p> | <p>NA3,5</p> | <p>NG3,5</p> | <p>1 max. force 180 N</p> | <p>OA3,5</p> <p>OG3,5</p> |

Accessories M5x0.8

AGS-15

Metric

| | | | | |
|---|--|---|--|---|
| <p>A Eye</p> <p>1 max. force 400 N</p> | <p>C Angle Ball Joint DIN 71802</p> <p>1 max. force 500 N</p> | <p>D Clevis Fork DIN 71752</p> <p>1 max. force 800 N</p> | <p>E Swivel Eye DIN 648</p> <p>1 max. force 800 N</p> | <p>F Inline Ball Joint</p> <p>Attention! Must only be used with compression loads.</p> <p>1 max. force 500 N</p> |
| <p>H Ball Socket DIN 71805</p> <p>1 max. force 500 N</p> | <p>1 max. force 500 N</p> | <p>MA5</p> | <p>1 max. force 400 N</p> | <p>NA5</p> <p>NG5</p> |
| <p>1 max. force 500 N</p> | <p>GSB-01</p> | <p>*GSB-02</p> | <p>1 max. force 500 N</p> | <p>PA5</p> <p>PG5</p> |

1 Attention! Max. static load in Newtons. Beware force increase during compression (progression) and observe max. force limit

*C end fitting, minus threaded stud, adapts to GSB-02.

Accessories M8x1.25

AGS-19, AGS-22, GZ-19

Imperial

| | | | | | | | |
|---|--|---|---|---|----------------------|-------------------|-------------------|
| <p>A Eye</p> <p>1 max. force 674 lbs</p> | <p>C Angle Ball Joint DIN 71802</p> <p>1 max. force 270 lbs</p> | <p>D Clevis Fork DIN 71752</p> <p>1 max. force 674 lbs</p> | <p>E Swivel Eye DIN 648</p> <p>1 max. force 674 lbs</p> | <p>F Inline Ball Joint</p> <p>Attention! Must only be used with compression loads.</p> <p>1 max. force 270 lbs</p> | | | |
| <p>H Ball Socket DIN 71805</p> <p>1 max. force 270 lbs</p> | <p>1 max. force 405 lbs</p> <p>MA8 ME8</p> | | <p>1 max. force 225 lbs</p> <p>NA8 NE8 NG8</p> | | | | |
| <p>1 max. force 270 lbs</p> | <p>GSB-03</p> | <p>OE8</p> | <p>*GSB-06</p> | <p>1 max. force 270 lbs</p> | <p>GSB-04</p> | <p>PE8</p> | <p>PG8</p> |

Accessories M10x1.5

AGS-28, GZ-28

Imperial

| | | | | | |
|---|--|---|--|---|--|
| <p>A Eye</p> <p>1 max. force 2,248 lbs</p> | <p>C Angle Ball Joint DIN 71802</p> <p>1 max. force 405 lbs</p> | <p>D Clevis Fork DIN 71752</p> <p>1 max. force 2,248 lbs</p> | <p>E Swivel Eye DIN 648</p> <p>1 max. force 2,248 lbs</p> | <p>F Inline Ball Joint</p> <p>Attention! Must only be used with compression loads.</p> <p>1 max. force 405 lbs</p> | |
| <p>1 max. force 405 lbs</p> | <p>MA10 ME10</p> | | <p>GSB-05 for AGS-19, 22 & 28, GZ-19 & 28</p> <p>1 max. force 405 lbs</p> <p>Bolt, nut, spacer included</p> | | |
| <p>1 max. force 270 lbs</p> | <p>OE10</p> | <p>1 max. force 270 lbs</p> | <p>PE10</p> | | |

1 Attention! Max. static load in pounds (lbs). Beware force increase during compression (progression) and observe max. force limit.

*AGS 19 & 22: C end fitting, minus threaded stud, adapts to GSB-06.

Accessories M8x1.25

AGS-19, AGS-22, GZ-19

Metric

| | | | | | | |
|---|--|---|---|---|--|--|
| <p>A Eye</p> <p>1 max. force 3,000 N</p> | <p>C Angle Ball Joint DIN 71802</p> <p>1 max. force 1,200 N</p> | <p>D Clevis Fork DIN 71752</p> <p>1 max. force 3,000 N</p> | <p>E Swivel Eye DIN 648</p> <p>1 max. force 3,000 N</p> | <p>F Inline Ball Joint</p> <p>Attention! Must only be used with compression loads.</p> <p>1 max. force 1,200 N</p> | | |
| <p>H Ball Socket DIN 71805</p> <p>1 max. force 1,200 N</p> | <p>1 max. force 1,800 N</p> <p>MA8 ME8</p> | | <p>1 max. force 1,000 N</p> <p>NA8 NE8 NG8</p> | | | |
| <p>1 max. force 1,200 N</p> | <p>GSB-03</p> | <p>OE8</p> | <p>*GSB-06</p> | <p>1 max. force 1,200 N</p> <p>GSB-04 PE8 PG8</p> | | |

Accessories M10x1.5

AGS-28, GZ-28

Metric

| | | | | | |
|--|--|--|--|---|--|
| <p>A Eye</p> <p>1 max. force 10,000 N</p> | <p>C Angle Ball Joint DIN 71802</p> <p>1 max. force 1,800 N</p> | <p>D Clevis Fork DIN 71752</p> <p>1 max. force 10,000 N</p> | <p>E Swivel Eye DIN 648</p> <p>1 max. force 10,000 N</p> | <p>F Inline Ball Joint</p> <p>Attention! Must only be used with compression loads.</p> <p>1 max. force 1,800 N</p> | |
| <p>1 max. force 1,800 N</p> | <p>MA10</p> | <p>ME10</p> | <p>GSB-05 for AGS-19, 22 & 28, GZ-19 & 28</p> <p>1 max. force 1,800 N</p> <p>Bolt, nut, spacer included</p> | | |
| <p>1 max. force 1,200 N</p> | <p>OE10</p> | <p>1 max. force 1,200 N</p> <p>PE10</p> | | | |

¹ Attention! Max. static load in Newtons. Beware force increase during compression (progression) and observe max. force limit.

*AGS 19 & 22: C end fitting, minus threaded stud, adapts to GSB-06.

Accessories M14x1.5

GS-40, GST-40, GZ-40

Imperial

| | | | | |
|--|---|--|---|--|
| <p>A Eye</p> <p>¹ max. force 2,248 lbs</p> | <p>C Angle Ball Joint DIN 71802</p> <p>¹ max. force 674 lbs</p> | <p>D Clevis Fork DIN 71752</p> <p>¹ max. force 2,248 lbs</p> | <p>E Swivel Eye DIN 648</p> <p>¹ max. force 2,248 lbs</p> | <p>F Inline Ball Joint</p> <p>Attention! Must only be used with compression loads.</p> <p>¹ max. force 719 lbs</p> |
| <p>¹ max. force 2,248 lbs</p> | <p>ME14</p> | <p>¹ max. force 2,248 lbs</p> | <p>ND14</p> | |

¹ Attention! Max. static load in pounds (lbs). Beware force increase during compression (progression) and observe max. force limit.

Accessories M24x2

GS-70

Imperial

| | | | |
|---|--|---|--------------------|
| <p>D24 Clevis Fork DIN 71752</p> <p>¹ max. force 11,240 lbs</p> | <p>E24 Swivel Eye DIN 648</p> <p>¹ max. force 11,240 lbs</p> | | |
| <p>¹ max. force 11,240 lbs</p> | <p>ME24</p> | <p>¹ max. force 11,240 lbs</p> | <p>ND24</p> |

¹ Attention! Max. static load in pounds (lbs). Beware force increase during compression (progression) and observe max. force limit.

Accessories M14x1.5 GS-40, GST-40, GZ-40 Metric

| | | | | |
|---|--|---|--|---|
| <p>A Eye</p> <p>1 max. force 10 ,000</p> | <p>C Angle Ball Joint DIN 71802</p> <p>1 max. force 3,000 N</p> | <p>D Clevis Fork DIN 71752</p> <p>1 max. force 10 ,000 N</p> | <p>E Swivel Eye DIN 648</p> <p>1 max. force 10 ,000</p> | <p>F Inline Ball Joint</p> <p>Attention! Must only be used with compression loads.</p> <p>1 max. force 3,200 N</p> |
| <p>1 max. force 10 ,000</p> <p>ME14</p> | <p>1 max. force 10 000 N</p> <p>ND14</p> | | | |

¹ Attention! Max. static load in Newtons. Beware force increase during compression (progression) and observe max. force limit.

Accessories M24x2 GS-70 Metric

| | |
|---|--|
| <p>D24 Clevis Fork DIN 71752</p> <p>1 max. force 50 ,000 N</p> | <p>E24 Swivel Eye DIN 648</p> <p>1 max. force 50 ,000 N</p> |
| <p>1 max. force 50 ,000 N</p> <p>ME24</p> | <p>1 max. force 50 ,000 N</p> <p>ND24</p> |

¹ Attention! Max. static load in Newtons. Beware force increase during compression (progression) and observe max. force limit.

Accessories M3.5x0.6

GS-8-V4A, GS-10-V4A, GS-12-V4A, GZ-15-V4A

Imperial

| | | | |
|---|--|---|---|
| <p>A3,5-V4A Eye</p> <p>1 max. force 83 lbs</p> | <p>C3,5-V4A Angle Ball Joint</p> <p>1 max. force 83 lbs</p> | <p>D3,5-V4A Clevis Fork</p> <p>1 max. force 83 lbs</p> | <p>G3,5-V4A Ball Socket</p> <p>1 max. force 83 lbs</p> |
| <p>1 max. force 40 lbs</p> | <p>NA3,5-V4A NG3,5-V4A</p> | <p>1 max. force 40 lbs</p> | <p>OA3,5-V4A OG3,5-V4A</p> |

Accessories M5x0.8

GS-15-VA, GS-15-V4A

Imperial

| | | | | |
|--|--|--|---|---|
| <p>A5-VA, V4A Eye</p> <p>1 max. force 110 lbs</p> | <p>C5-VA, V4A Angle Ball Joint</p> <p>1 max. force 97 lbs</p> | <p>D5-VA, V4A Clevis Fork</p> <p>1 max. force 110 lbs</p> | <p>E5-VA, V4A Swivel Eye</p> <p>1 max. force 110 lbs</p> | <p>G5-VA, V4A Ball Socket</p> <p>1 max. force 97 lbs</p> |
| <p>1 max. force 112 lbs</p> | <p>MA5-V4A</p> | <p>1 max. force 90 lbs</p> | <p>NA5-V4A NG5-V4A</p> | |
| <p>1 max. force 40 lbs</p> | <p>OA5-V4A OG5-V4A</p> | <p>1 max. force 112 lbs</p> | <p>PA5-V4A PG5-V4A</p> | |

¹ Attention! Max. static load in pounds (lbs). Beware force increase during compression (progression) and observe max. force limit.

Accessories M3.5x0.6

GS-8-V4A, GS-10-V4A, GS-12-V4A, GZ-15-V4A

Metric

| | | | |
|--|---|--|--|
| <p>A3,5-V4A Eye</p> <p>1 max. force 370 N</p> | <p>C3,5-V4A Angle Ball Joint</p> <p>1 max. force 370 N</p> | <p>D3,5-V4A Clevis Fork</p> <p>1 max. force 370 N</p> | <p>G3,5-V4A Ball Socket</p> <p>1 max. force 370 N</p> |
| <p>1 max. force 180 N</p> | <p>NA3,5-V4A NG3,5-V4A</p> | <p>1 max. force 180 N</p> | <p>OA3,5-V4A OG3,5-V4A</p> |

Accessories M5x0.8

GS-15-VA, GS-15-V4A

Metric

| | | | | |
|--|---|--|---|--|
| <p>A5-VA, V4A Eye</p> <p>1 max. force 490 N</p> | <p>C5-VA, V4A Angle Ball Joint</p> <p>1 max. force 430 N</p> | <p>D5-VA, V4A Clevis Fork</p> <p>1 max. force 490 N</p> | <p>E5-VA, V4A Swivel Eye</p> <p>1 max. force 490 N</p> | <p>G5-VA, V4A Ball Socket</p> <p>1 max. force 430 N</p> |
| <p>1 max. force 500 N</p> | <p>MA5-V4A</p> | <p>1 max. force 400 N</p> | <p>NA5-V4A NG5-V4A</p> | |
| <p>1 max. force 180 N</p> | <p>OA5-V4A OG5-V4A</p> | <p>1 max. force 500 N</p> | <p>PA5-V4A PG5-V4A</p> | |

¹ Attention! Max. static load in Newtons. Beware force increase during compression (progression) and observe max. force limit.

Accessories M8x1.25 GS-19-VA, GS-22-VA, GZ-19-VA, GS-19-V4A, GS-22-V4A, GZ-19-V4A Imperial

| | | | | | |
|--|---|--|---|--|-----------------------|
| <p>A8-VA, V4A Eye</p> <p>1 max. force 351 lbs</p> | <p>C8-VA, V4A Angle Ball Joint</p> <p>1 max. force 256 lbs</p> | <p>D8-VA, V4A Clevis Fork</p> <p>1 max. force 351 lbs</p> | <p>E8-VA, V4A Swivel Eye</p> <p>1 max. force 351 lbs</p> | <p>G8-VA, V4A Ball Socket</p> <p>1 max. force 256 lbs</p> | |
| <p>1 max. force 405 lbs</p> | <p>MA8-V4A</p> | <p>1 max. force 225 lbs</p> | <p>NA8-V4A</p> | <p>NG8-V4A</p> | |
| <p>1 max. force 270 lbs</p> | <p>OA8-V4A</p> | <p>OG8-V4A</p> | <p>1 max. force 270 lbs</p> | <p>PA8-V4A</p> | <p>PG8-V4A</p> |

Accessories M10x1.5 GS-28-VA, GZ-28-VA, GS-28-V4A, GZ-28-V4A Imperial

| | | | |
|---|--|---|--|
| <p>A10-VA, V4A Eye</p> <p>1 max. force 854 lbs</p> | <p>C10-VA, V4A Angle Ball Joint</p> <p>1 max. force 393 lbs</p> | <p>D10-VA, V4A Clevis Fork</p> <p>1 max. force 854 lbs</p> | <p>E10-VA, V4A Swivel Eye</p> <p>1 max. force 854 lbs</p> |
| <p>1 max. force 405 lbs</p> | <p>MA10-V4A</p> | | |

1 Attention! Max. static load in pounds (lbs). Beware force increase during compression (progression) and observe max. force limit.

Accessories M8x1.25 GS-19-VA, GS-22-VA, GZ-19-VA, GS-19-V4A, GS-22-V4A, GZ-19-V4A Metric

| | | | | | |
|--|---|--|---|--|-----------------------|
| <p>A8-VA, V4A Eye</p> <p>1 max. force 1,560 N</p> | <p>C8-VA, V4A Angle Ball Joint</p> <p>1 max. force 1,140 N</p> | <p>D8-VA, V4A Clevis Fork</p> <p>1 max. force 1,560 N</p> | <p>E8-VA, V4A Swivel Eye</p> <p>1 max. force 1,560 N</p> | <p>G8-VA, V4A Ball Socket</p> <p>1 max. force 1,140 N</p> | |
| <p>1 max. force 1,800 N</p> | <p>MA8-V4A</p> | <p>1 max. force 1,000 N</p> | <p>NA8-V4A</p> | <p>NG8-V4A</p> | |
| <p>1 max. force 1,200 N</p> | <p>OA8-V4A</p> | <p>OG8-V4A</p> | <p>1 max. force 1,200 N</p> | <p>PA8-V4A</p> | <p>PG8-V4A</p> |

Accessories M10x1.5 GS-28-VA, GZ-28-VA, GS-28-V4A, GZ-28-V4A Metric

| | | | |
|---|--|---|--|
| <p>A10-VA, V4A Eye</p> <p>1 max. force 3,800 N</p> | <p>C10-VA, V4A Angle Ball Joint</p> <p>1 max. force 1,750 N</p> | <p>D10-VA, V4A Clevis Fork</p> <p>1 max. force 3,800 N</p> | <p>E10-VA, V4A Swivel Eye</p> <p>1 max. force 3,800 N</p> |
| <p>1 max. force 1,800 N</p> | <p>MA10-V4A</p> | | |

¹ Attention! Max. static load in Newtons. Beware force increase during compression (progression) and observe max. force limit.

Accessories M14x1.5 GS-40-VA, GZ-40-VA, GS-40-V4A, GZ-40-V4A Imperial

| | | | |
|--|---|--|---|
| <p>A14-VA, V4A Eye</p> <p>1 max. force 1,574 lbs</p> | <p>C14-VA, V4A Angle Ball Joint</p> <p>1 max. force 719 lbs</p> | <p>D14-VA, V4A Clevis Fork</p> <p>1 max. force 1,574 lbs</p> | <p>E14-VA, V4A Swivel Eye</p> <p>1 max. force 1,574 lbs</p> |
| <p>1 max. force 2,248 lbs</p> | <p>ME14-VA</p> | <p>1 max. force 2,248 lbs</p> | <p>ND14-VA</p> |

¹ Attention! Max. static load in pounds (lbs). Beware force increase during compression (progression) and observe max. force limit.

Accessories M14x1.5 GS-40-VA, GZ-40-VA, GS-40-V4A, GZ-40-V4A Metric

| | | | |
|--|---|--|---|
| <p>A14-VA, V4A Eye</p> <p>1 max. force 7,000 N</p> | <p>C14-VA, V4A Angle Ball Joint</p> <p>1 max. force 3,200 N</p> | <p>D14-VA, V4A Clevis Fork</p> <p>1 max. force 7,000 N</p> | <p>E14-VA, V4A Swivel Eye</p> <p>1 max. force 7,000 N</p> |
| <p>1 max. force 10,000 N</p> | <p>ME14-VA</p> | <p>1 max. force 10,000 N</p> | <p>ND14-VA</p> |

¹ Attention! Max. static load in Newtons. Beware force increase during compression (progression) and observe max. force limit.

WARNING – USER RESPONSIBILITY
FAILURE OR IMPROPER SELECTION OR IMPROPER USE OF THE PRODUCTS DESCRIBED HEREIN OR RELATED ITEMS
CAN CAUSE DEATH, PERSONAL INJURY AND PROPERTY DAMAGE

This document and other information from Kaydon Corporation, its subsidiaries and authorized distributors provide product or system options for further investigation by users having technical expertise. The user, through its own analysis and testing, is solely responsible for making the final selection of the system and components and assuring that all performance, endurance, maintenance, safety and warning requirements of the application are met. The user must analyze all aspects of the application, follow applicable industry standards, and follow the information concerning the product in the current product catalog and in any other materials provided from Kaydon or its subsidiaries or authorized distributors. To the extent that Kaydon or its subsidiaries or authorized distributors provide component or system options based upon data or specifications provided by the user, the user is responsible for determining that such data and specifications are suitable and sufficient for all applications and foreseeable uses of the components or systems. ACE Controls Inc. is a business unit of Kaydon Corporation.

Adjustment Instructions Valve



Adjustment Instruction

1. Hold gas spring piston rod down.
2. Remove any fitting attached to the body end of the gas spring (GZ-19 to GZ-40 version the piston rod).
3. Insert adjuster knob on thread end on the cylinder body (on GZ-19 to GZ-40 version thread end on the piston rod). When resistance is felt, proceed slowly and with caution. This opens the valve and you can hear the nitrogen escaping and reducing pressure. Turn back the adjusting knob immediately, to avoid too much nitrogen being discharged.
4. After adjustment, remove the adjuster knob, mount the end fittings and test the gas spring in your application. If necessary repeat the procedure.

If you use 2 gas springs in parallel, both gas springs should have the same force to avoid bending forces or side load on the application. If necessary return to ACE to refill both gas springs to the same (average) force. If too much nitrogen is discharged, the units can be returned to ACE for re-gassing.

Gas Spring Refilling Kit



The **ACE gas spring refilling kit** offers you the opportunity to fill gas springs on location or adapt them individually. The refilling kit is equipped with all the parts you need to fill gas springs. Very precise filling of the gas springs is possible using the digital manometer. The table for determining the filling pressure of the gas springs is included with the case. The only thing missing from the delivery is the nitrogen.

The refilling kit contains all filling bells and adjuster knobs for the current ACE gas spring range.

Ordering name: Complete gas spring refilling kit

Item number: GS-FK-Complete

"Independence and flexibility!"



The refilling kit suits 2,900 psi (200 bar) nitrogen bottles with a thread of CGA 680. Nitrogen bottles not included. Other connections are available upon request.

Gas springs filled with the refilling kit must be measured on a calibrated measurement system by ACE for repeat production.

ACE

ACE Product Catalogs

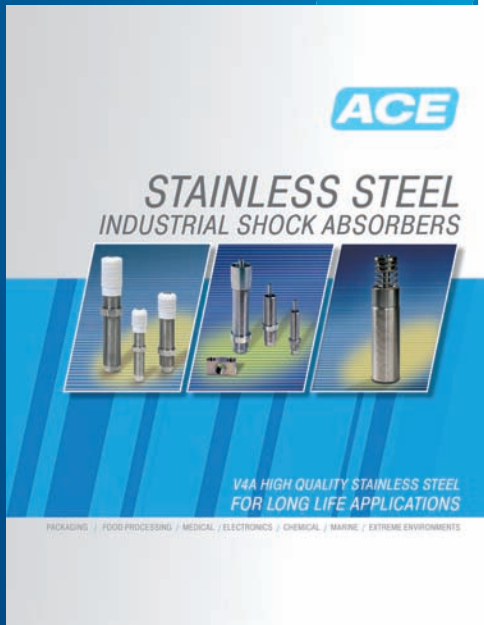
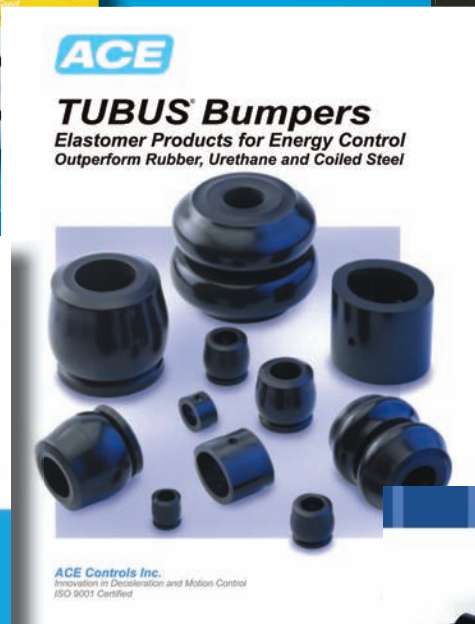
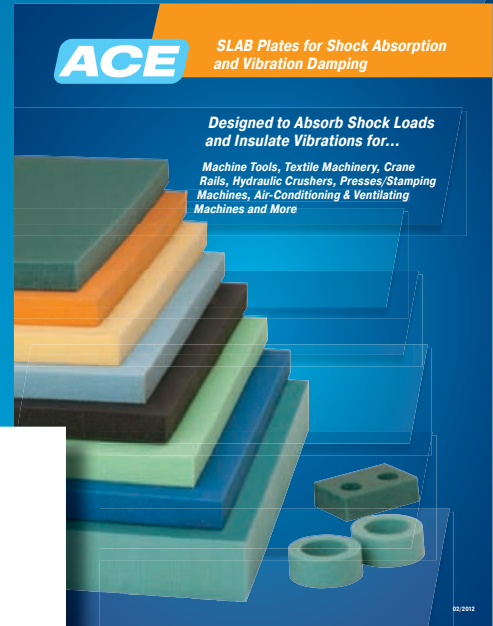
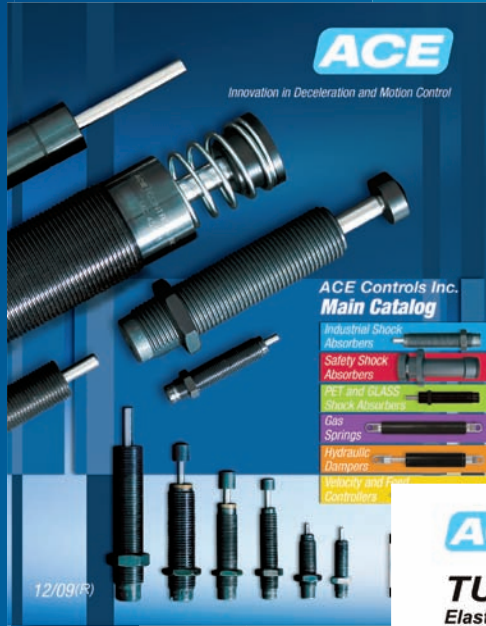

© ACE Controls Inc. 2012
All Rights Reserved
Catalog No. 200-0175

ACE Controls Inc. is focused on continuous improvement. Therefore, ACE reserves the right to change models, dimensions or specifications without notice or obligation.

WARNING: Improper selection or improper use of the products and/or systems described herein or related items can cause personal or fatal injury and/or property damage.

ACE

ACE Controls Inc. • 800-521-3320 • (248) 476-0213 • Fax (248) 476-2470 • www.acecontrols.com • email: shocks@acecontrols.com